



Advanced Training Parameters

All information in this document is subject to modification without prior notice. No part of this manual may be reproduced, stored in a database or retrieval system or published, in any form or in any way, electronically, mechanically, by print, photo print, microfilm or any other means without prior written permission from the publisher. SCIA is not responsible for any direct or indirect damage because of imperfections in the documentation and/or the software.

© Copyright 2016 SCIA nv. All rights reserved.

Table of contents

Table of contents	3
Preface	5
Beam on two supports	6
Cross-sections	11
General cross-section	11
Type of Cross-sections	14
Catalogue block	17
Plate on subsoil	21
Cellular beam	23
Beam with practical reinforcement	25
Ground-level	29
Layers	32
Steel hall	36
Plate with ribs	39
Plate with ribs_1.esa	39
Plate with ribs_2.esa	42
Tubular plates	44
Hollow core slab	50
XML	64
ODA	66
Batch optimizer	71
Example 14: User blocks & ProjectTemplates	77
User blocks.....	77
Project templates	80
General parameterizing	82
Type of parameters:	82
Possible formulae:.....	83
Possible operators in SCIA Engineer:.....	84

Preface

This workshop contains an assortment of examples on parameters.

What is the purpose of this functionality?

Suppose that a SCIA Engineer user handles nearly every day with the same type of structure.

Only the dimensions, cross-sections, height, number of spans, ... differs in the different projects. For this, the option '**Parameters**' can be used.

Every type -as mentioned above- can be parameterized.

The parameters are fully editable and when changed they may lead to a very straightforward modification of the calculated model.

What's more, a model defined by means of parameters can be saved as a template.

When opened, the user is first asked to fill in the table with all the parameters present in the model. This may be effectively used for creation of simple "programs" for e.g. calculation of continuous beam, simple frame, etc.

The user has to create the structure only once. Then he/she has to define the parameters and save the structure as template. In the future, he/she just fills in the table with a few parameters and can immediately proceed to calculation and evaluation of results.

This leads to a huge reduction of the working hours and will be more effective.

Above this, this workshop contains also some extra's which can help the user to become more effective in working with SCIA Engineer:

- **XML**: SCIA Engineer supports exporting and importing to/of this format.
- **ODA**: One dialog application
- **Batch optimizer**: The user can give a range of values to a parameter and the solution is also a range of results.
- **User blocks**: A project can be saved as a user block. Afterwards, this block can be imported in another project.
- **Project templates**: As mentioned before, the user can make a standard project which can be used for all the other projects.

Beam on two supports

A beam manufactured of C30/37 according to the EC-EN is supported on two ends. We will input parameters for the length and the cross-section dimensions.

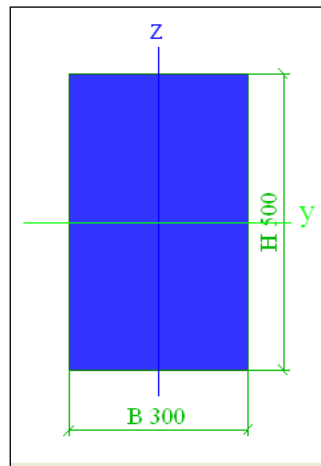
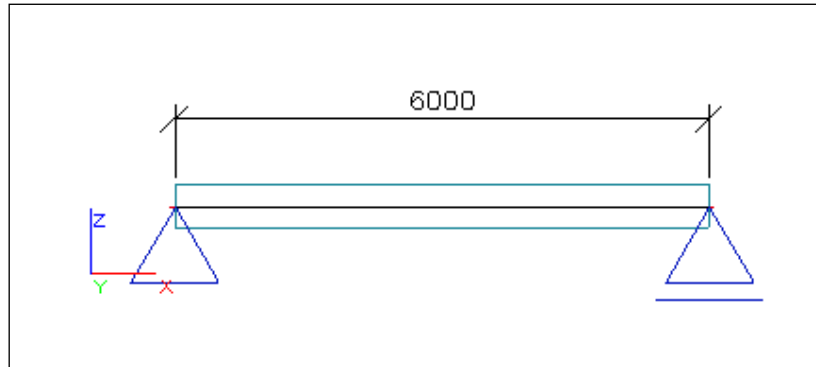

- Project data: - Construction type: Frame XZ
- Project level advanced

- Input support:  Support
 in node

Method

- After activating the functionality parameters, you will see the function



- The parameters get following properties with the values:
 - Length L: 10 m
 - Width B: 300 mm
 - Height H: 500 mm

- Next, go to:

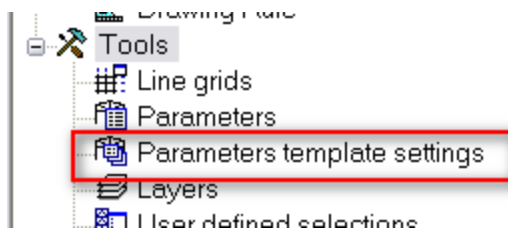

Here the template tabs are made

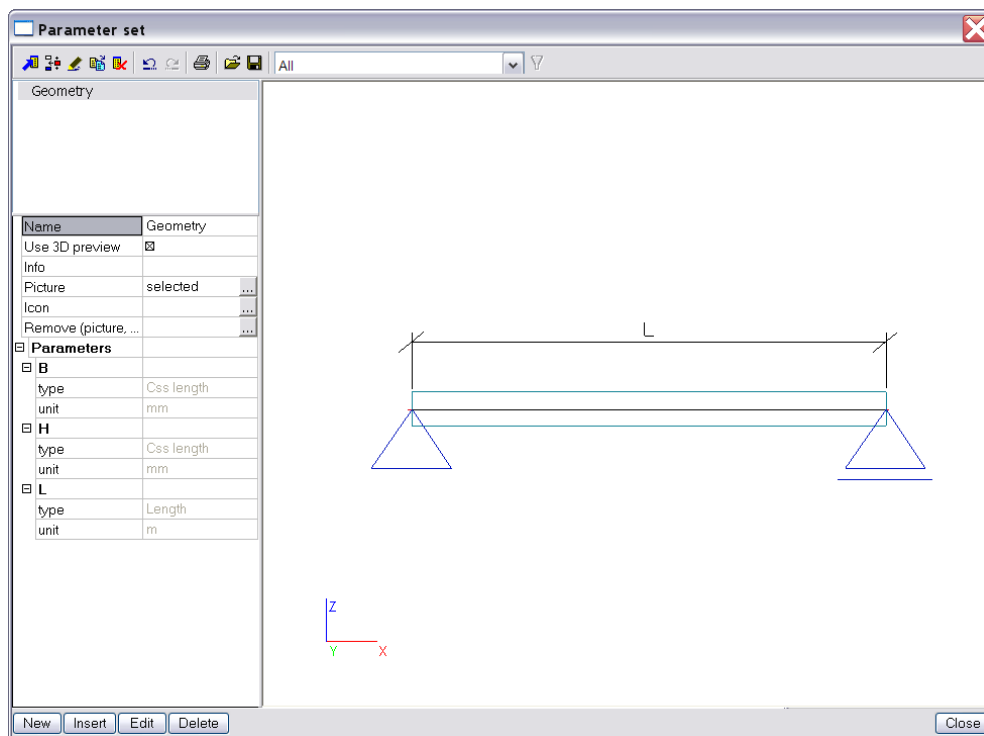

Remark: the introduction of the picture will be explained later.

- Subsequently you can use a new function:

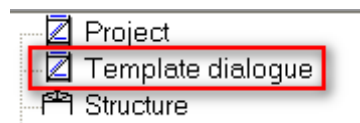

Here the values of the various parameters can be adapted.

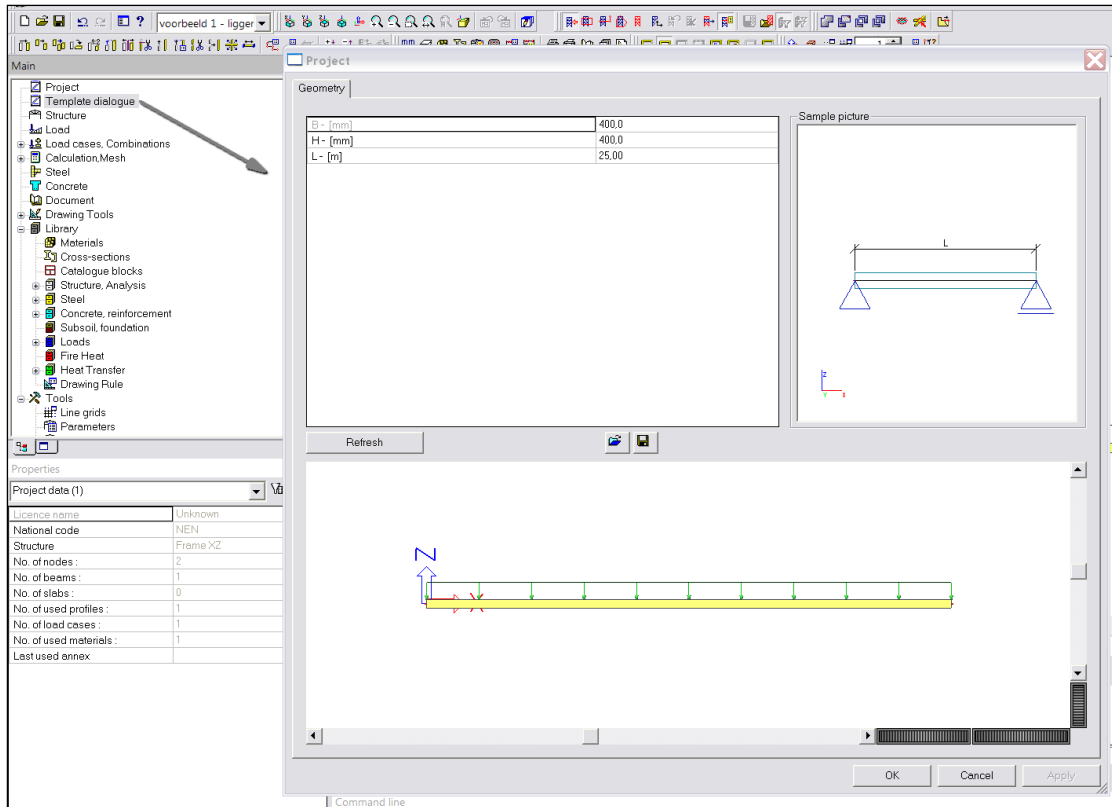

- The various parameters has to be attributed now to the cross-section and the length of the beam.

→ Length beam: X-coordinate of node K2:

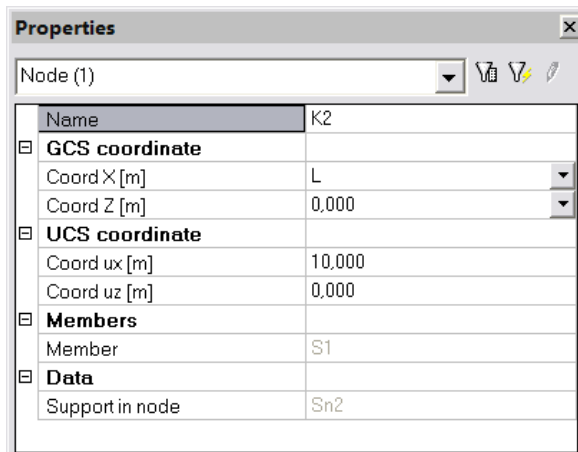

→ Width & height profile:

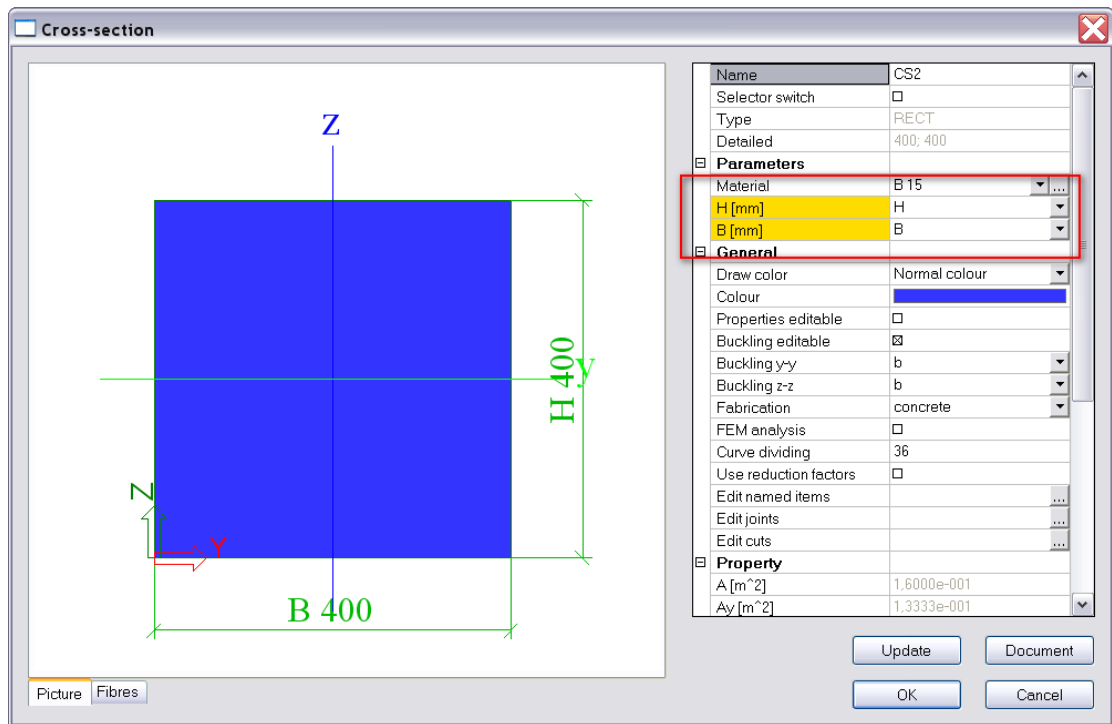

- Changing a parameter:

The value of the length L is adjusted of 10m to 20m.

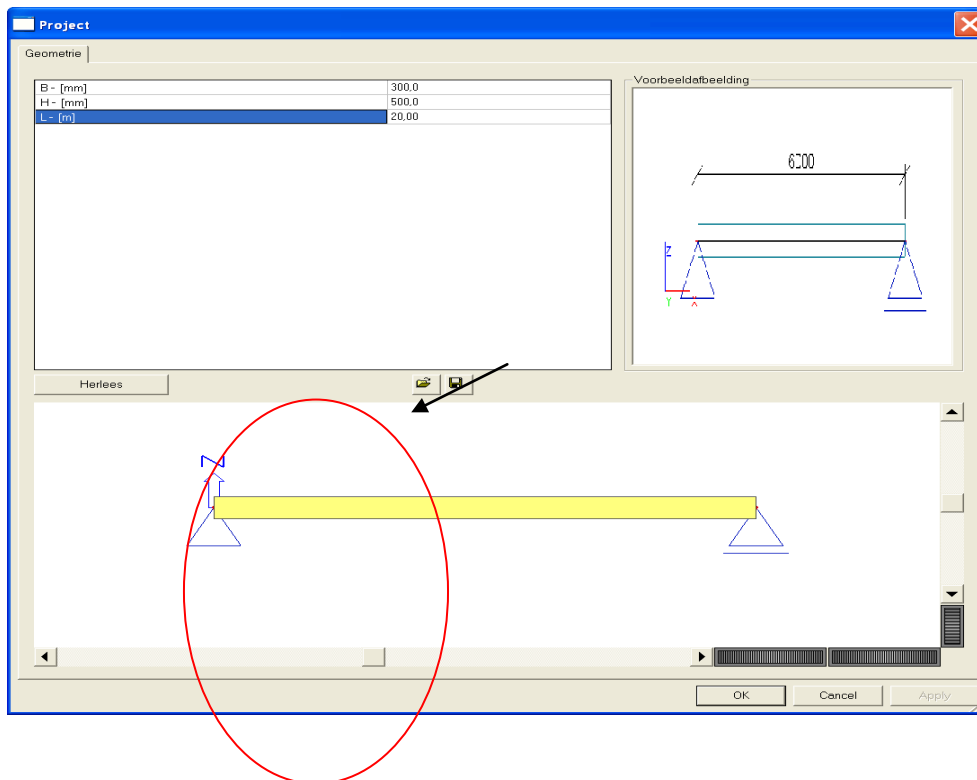

If you use 'Store users- default settings', you can make various compositions which you can load afterwards:

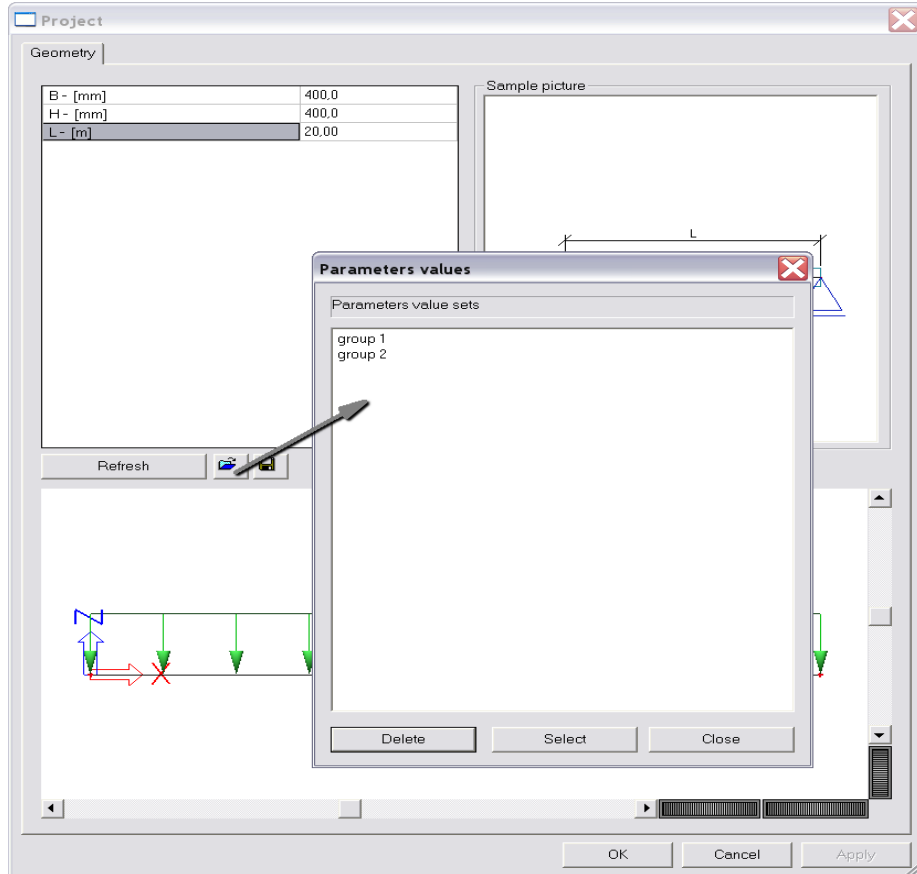

Cross-sections

The same example will be used to explain the type of parameters for cross-sections. For this 'Cross-sections.esa' can be used.

First of all the parameters for graphical cross-sections are explained. Next, the parameter for the type of cross-section will be shown.

General cross-section

- If the user decides to work with a graphical cross-section, the method of parameterizing is different from that of standard cross-sections.
- First of all parameters has to be created for the height en width of the cross-section.

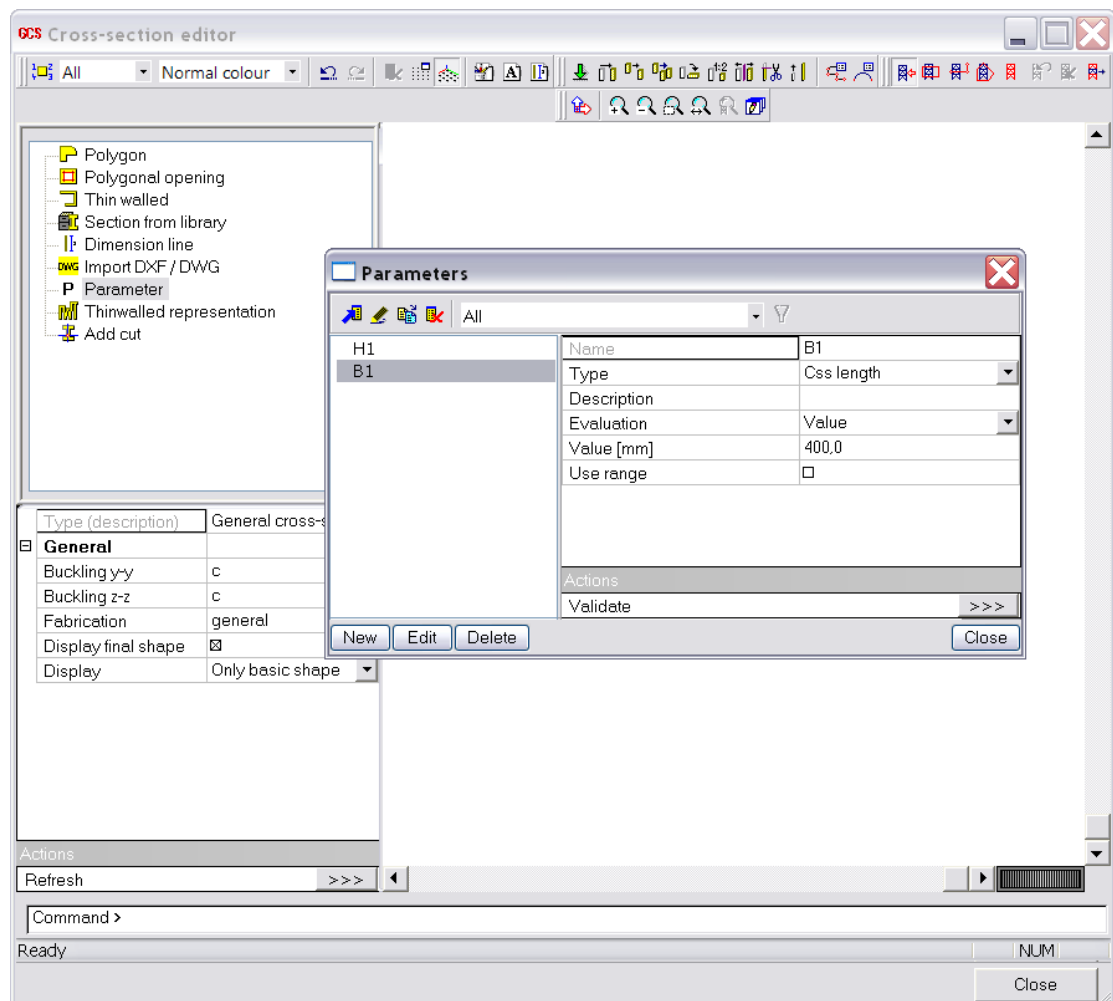

- Next, the polygon can be introduced and after this, the parameters can be attributed to the Y and Z coordinates:

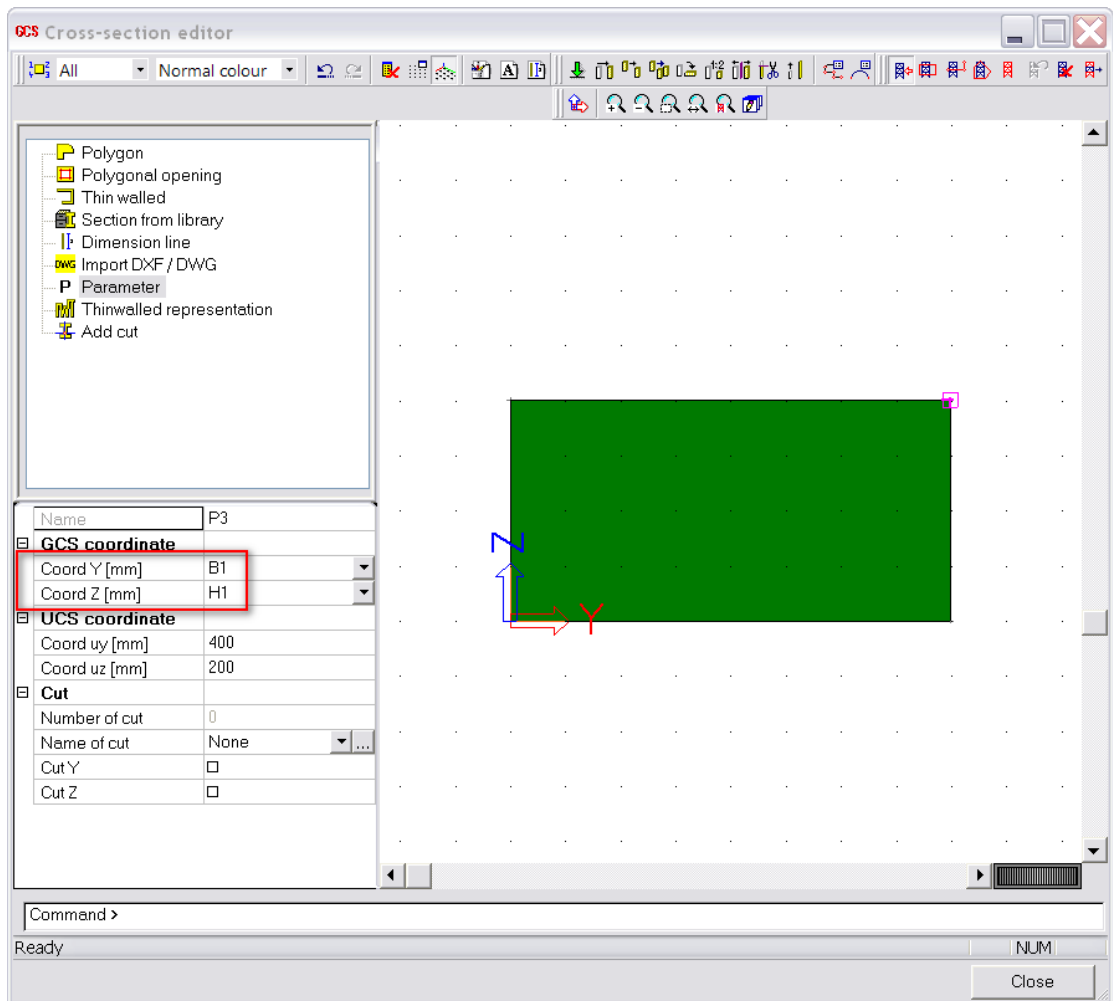

The difference with the parameters of a profile from a library is that here the parameters can be made in the cross-section editor itself.

- Above this, if the user wants to adapt these parameters, two parameters has to be created in 'Tools > Parameters'. Here, we can create the same parameters H1 and B1:

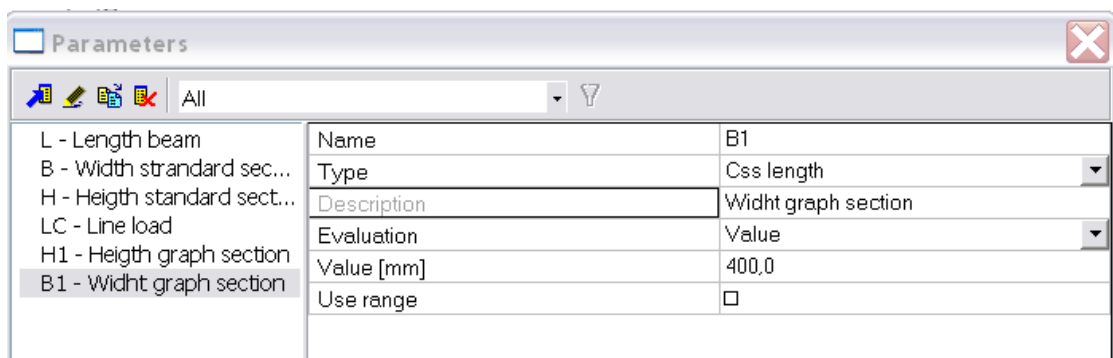

Note:

It's very important that you give a good description to your parameters. On that way, it simplifies afterwards the input and the adaptation of the parameters.

- These values can now be attributed to the properties of the profile:

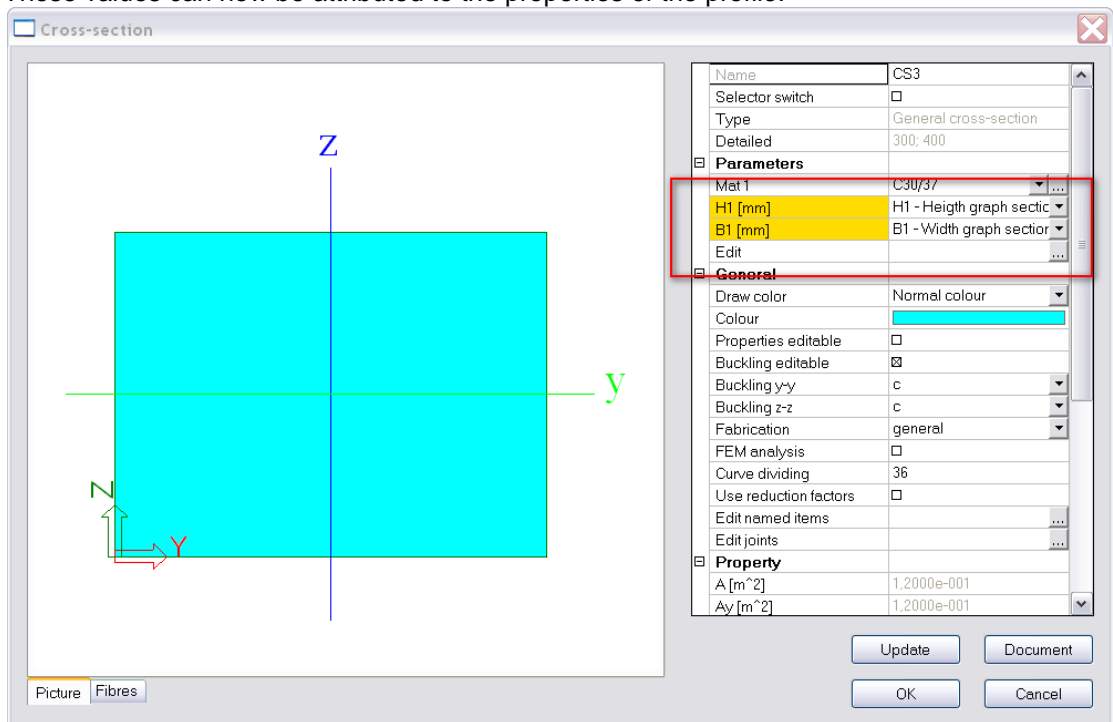

- To change these values, we can make a new tab in the 'Parameters template settings' and this will appear now in the 'Template dialogue':

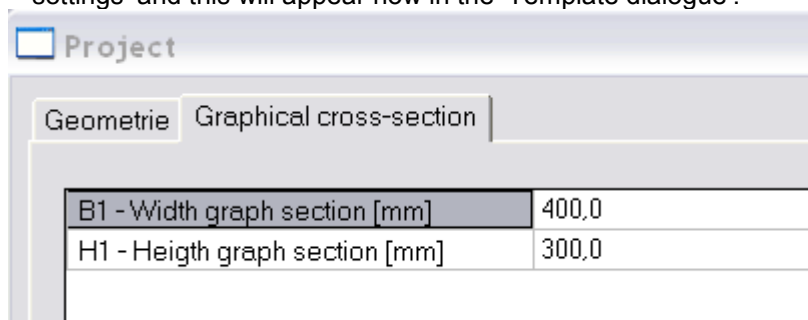

Type of Cross-sections

In SCIA Engineer it's also possible to parameterize libraries. Examples here are: Materials, cross-sections, reinforcement, subsoils,...

In this topic, we will explain it for the type of cross-sections.

The other library types can be handled with the same principle.

Again, this will be explained by means of example 'Cross-sections.esa'.

- Three cross-sections are inserted in the project:
CS1: RECT(400;400)
CS2: Graphical cross-section
CS3: CIRC (400)
- We define a 'master' cross-section. This cross-section is fictive and will be the parameter. For this, we copy arbitrarily CS1 and we call it 'Master'.
- For this master cross-section, the option 'Selector Switch' has to be checked and an Alternative profile can be choosen now:
- Creation of the parameter:

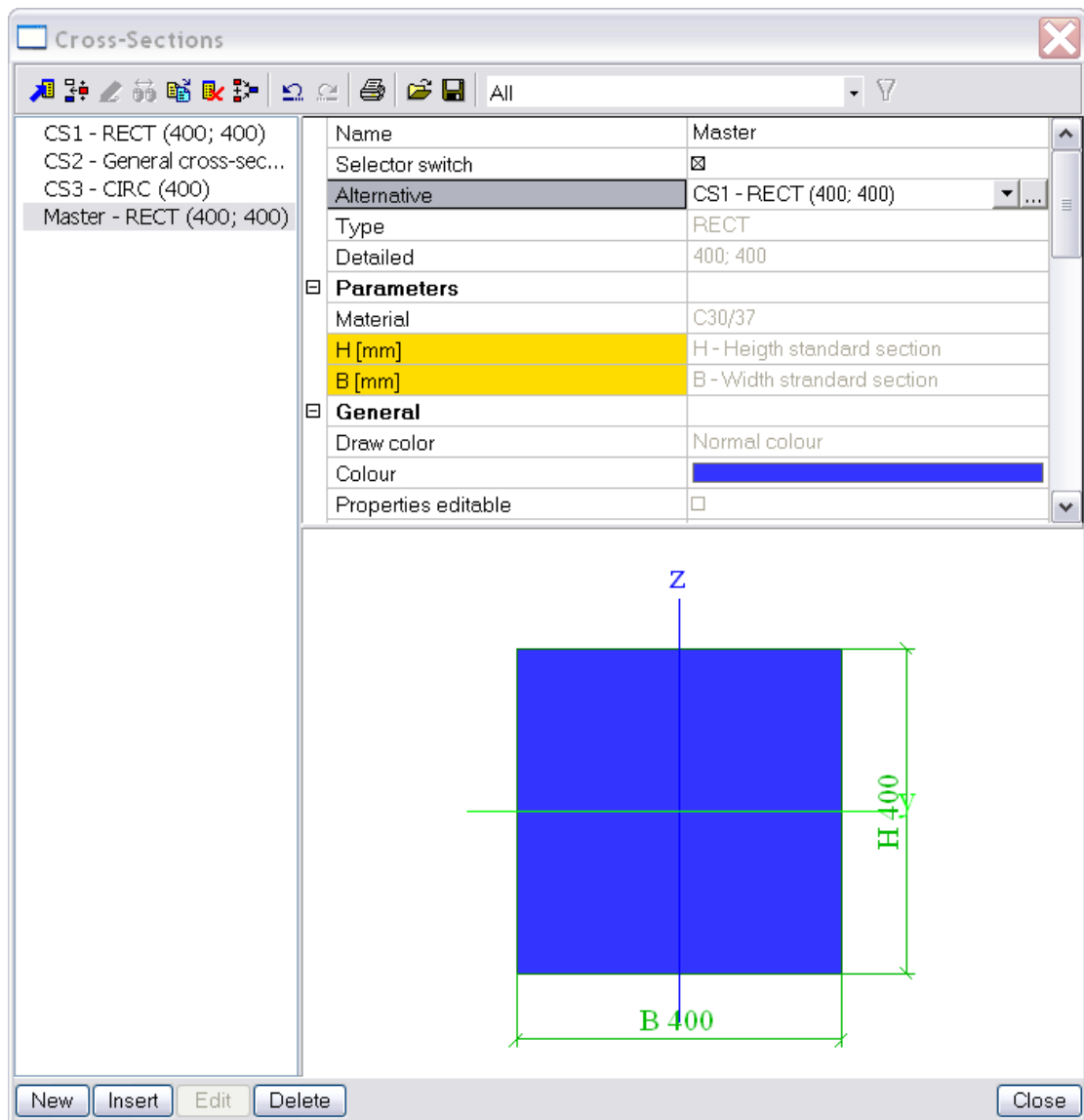

Without this option 'selector switch', we cannot use the parameter for the cross-section type.

- Go to 'Tools > Parameters' and the following parameter can be created:

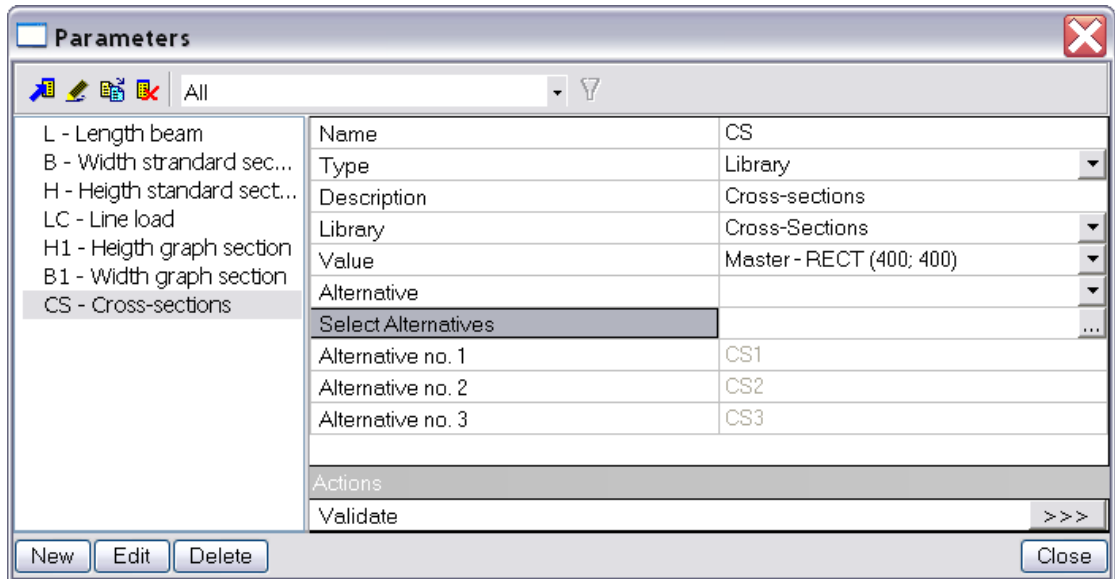

Type: Library

Library: Cross-sections

Value: Here the fictive 'master' cross-section can be input.

Alternative: One of the 3 alternatives can be chosen. This alternative will be the default profile.

Select Alternatives: The 3 alternatives can be inserted here

- Attribute this parameter to the cross-section type of the beam. Pay attention: The master profile becomes the parameter. But the content of this master will change after choosing another alternative:

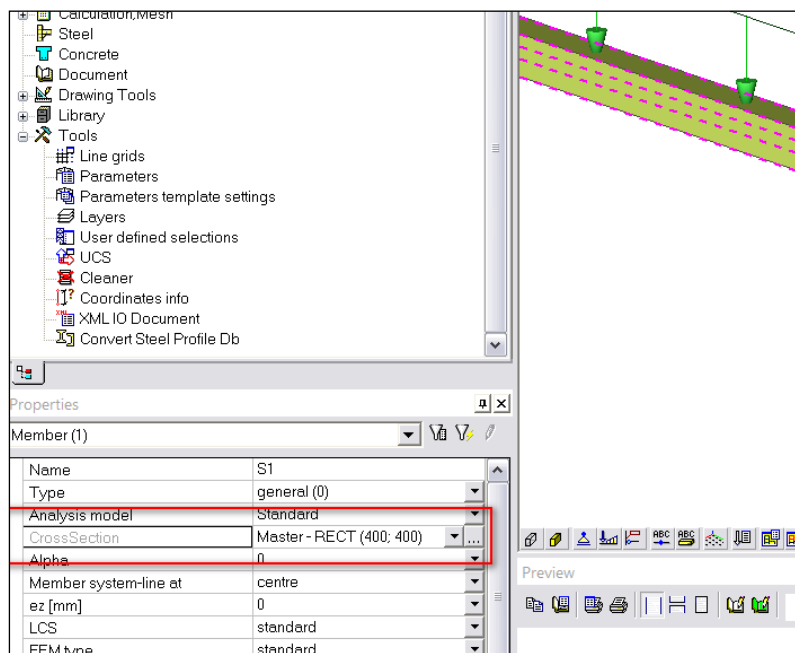

- After creating a new tab in 'Tools > Parameters Template settings', it appeared in the dialogue box of the 'Template Dialogue'. And again, this box can be used to change the cross-section type:

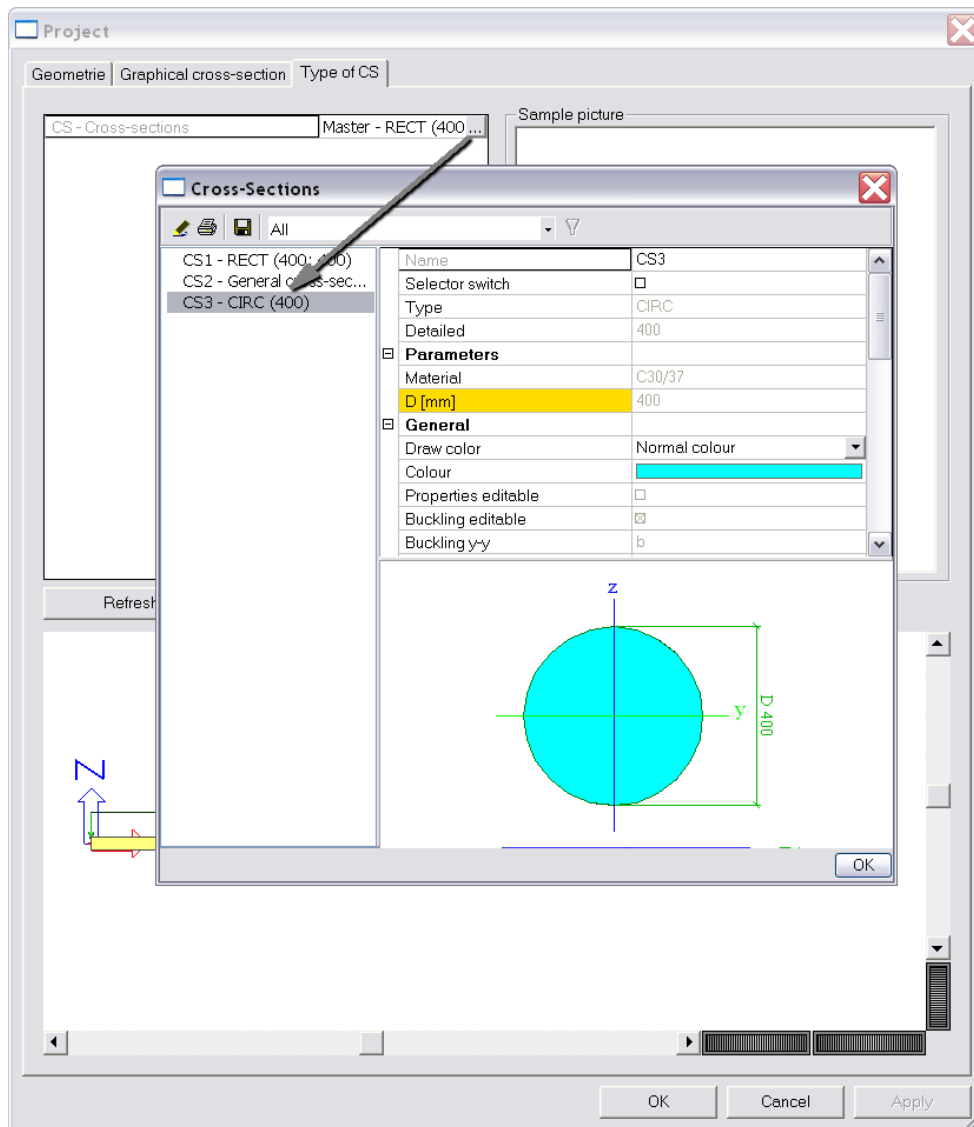

And this results into:

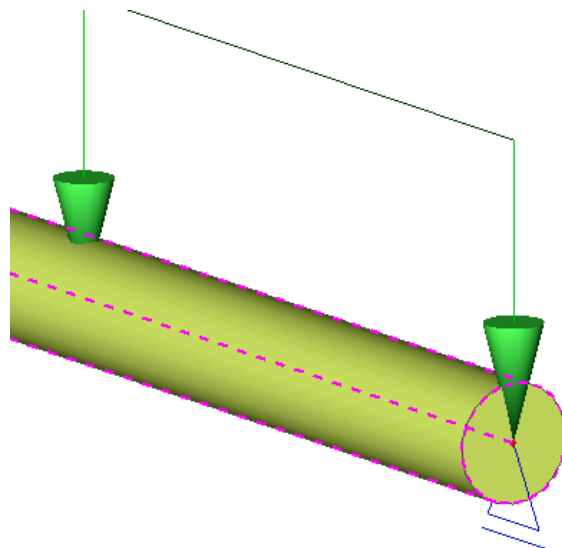

Catalogue block

In this example a catalogue block will be inserted. After the introduction of it, it will be parametrized.

- Project data: - Construction type: Frame XYZ
- Project level : advanced
- Go to 'Structure > Advanced input > Catalogue blocks'.

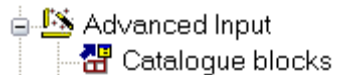

The first block in the menu 'Frame 2D' is chosen. We keep the standard configuration:

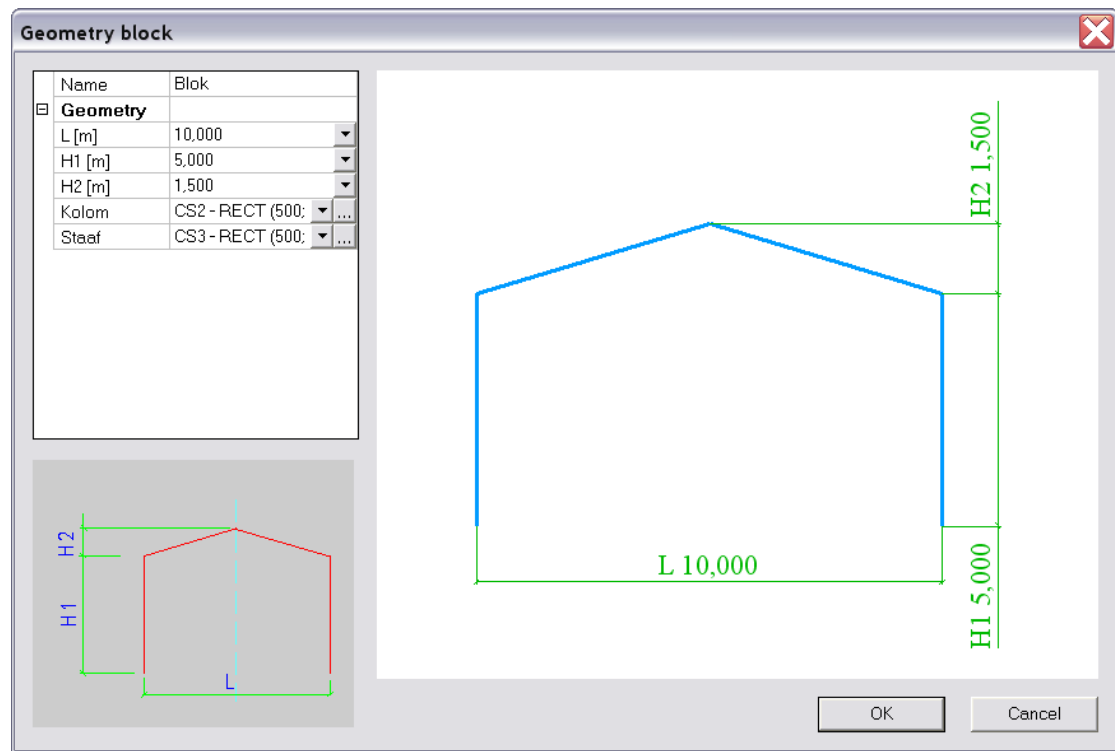

- Input support:  Support
 in node

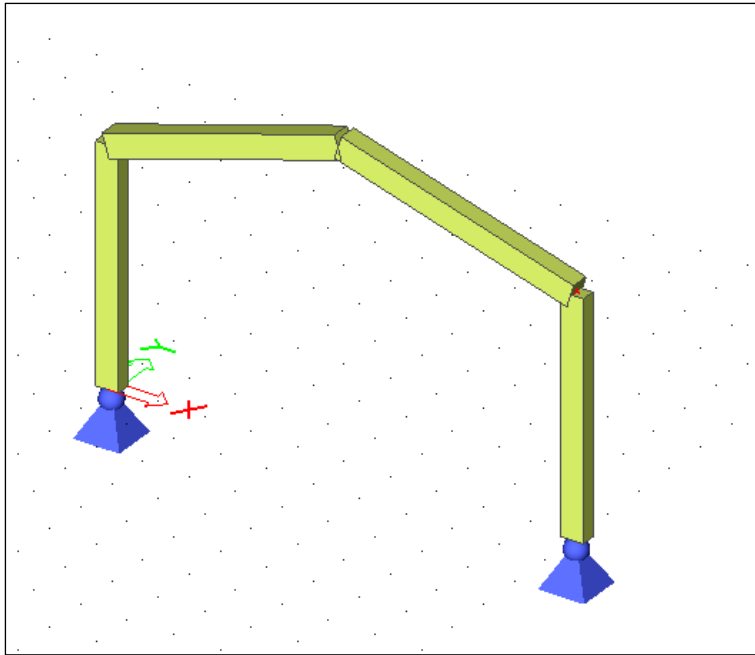

Method:

- First of all, the parameters will be created. Go to 'Tools > Parameters':

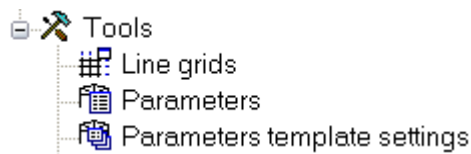

- The following properties are parameterized with a begin value of:
 1. Span L: 10 m
 2. Height H1: 5 m
 3. Height H2: 1,5 m
 4. Htot: H1 + H2
 5. Middle: L/2
 6. Rigidity support: $5 \cdot 10^{-6}$

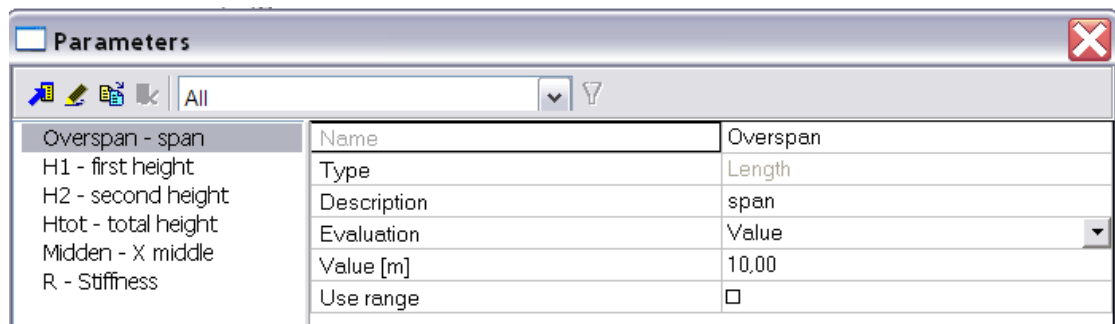

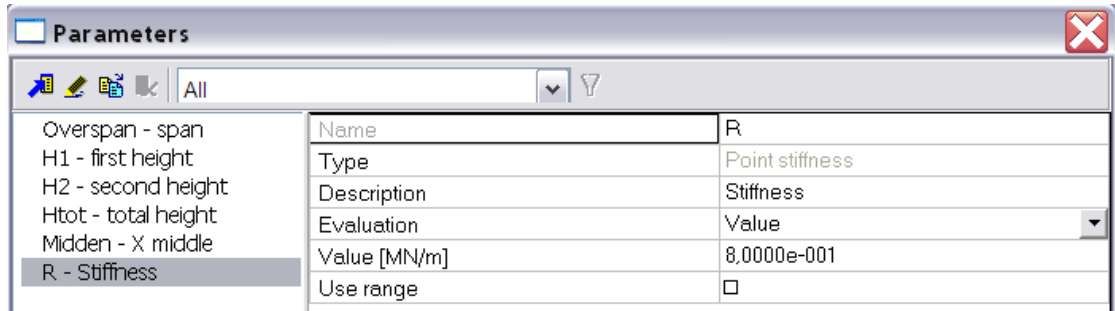
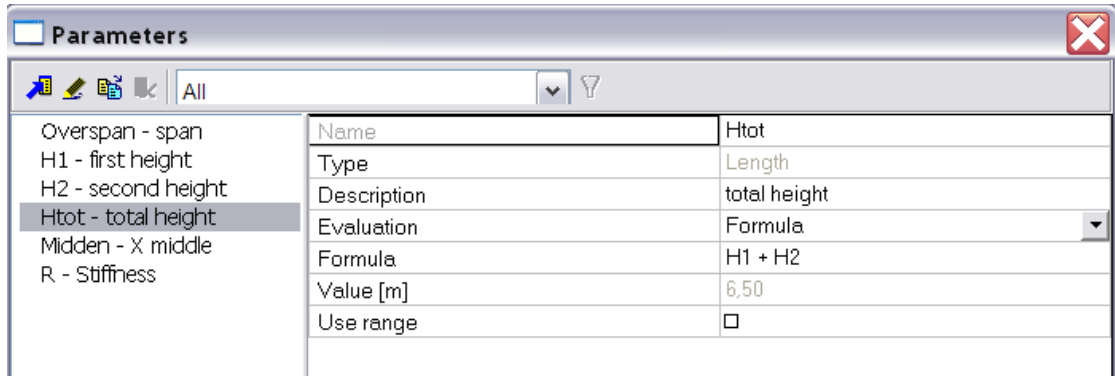

- When closing this window, the following question appears:

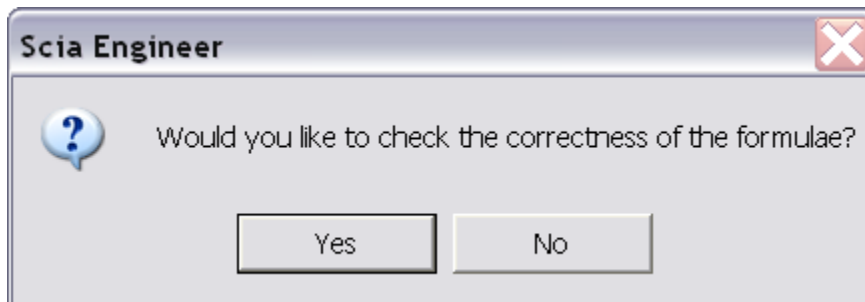

Click 'Yes' if formulae were used so they can be checked.

- Now the parameters are attributed to the various geometry-properties.
- Subsequently a line grid can be made:

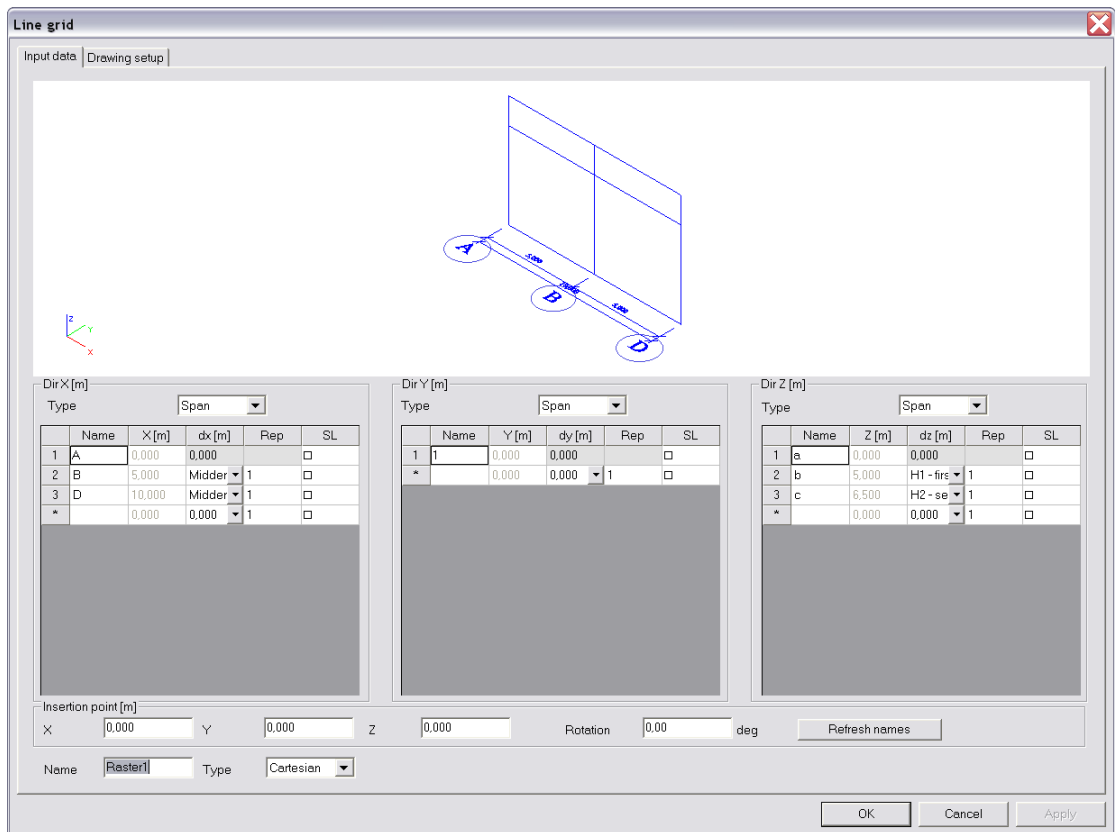

- The line grid can also obtain a parameter to adjust the view. This is possible through a binary parameter with a Boolean value (yes/no).

Plate on subsoil

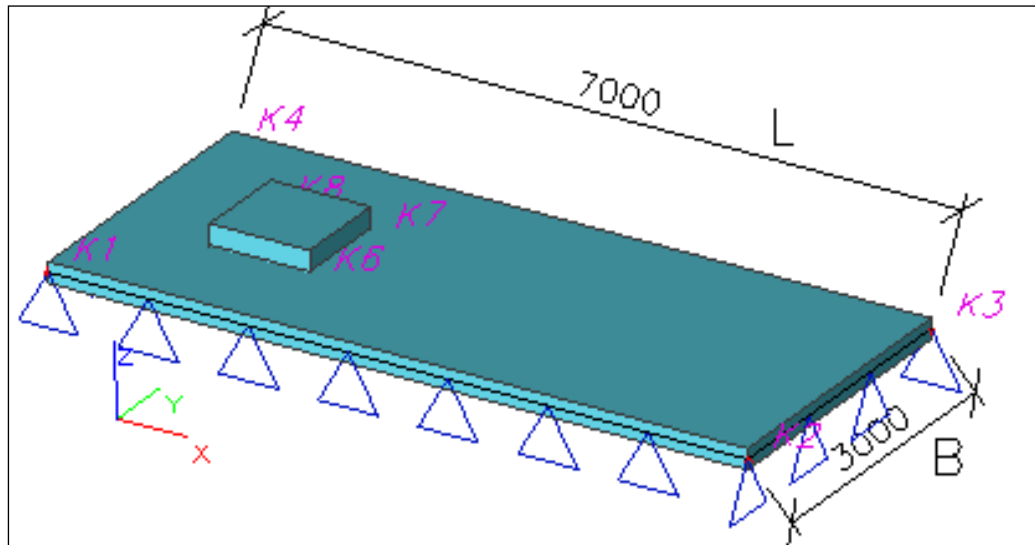

- Project data:
 - Construction type: General XYZ
 - Project level advanced
- Input support:
 - Support
 - in node
 - point on beam
 - line on beam
- Input subregion:
 - 2D member components
 - Subregion
- Load cases:
 - LC1: Selfweight
 - LC2: Permanent plane load q [kN/m²]
 - LC3: Free surface load on projected area: q [kN/m²]

Method

- The following parameters are applied:
 - Length L: 7 m
 - Width B: 3 m
 - Permanent plane load: 5 kN/m²
 - Free plane load : 2 kN/m²
 - Thickness plate d: 200 mm
 - Thickness subregion d1: 400 mm
- Adjusting the value of the free plane load:

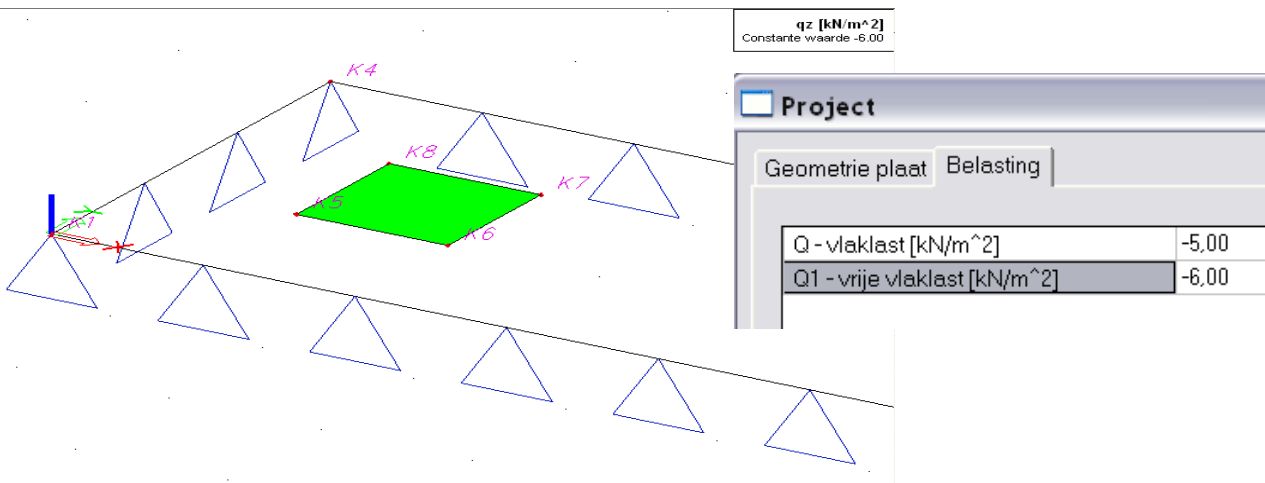
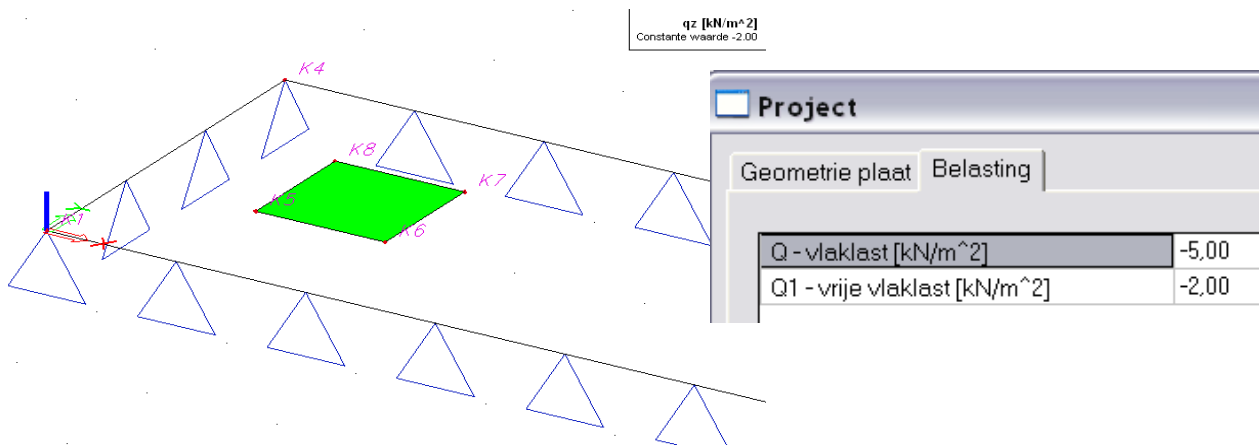

Cellular beam

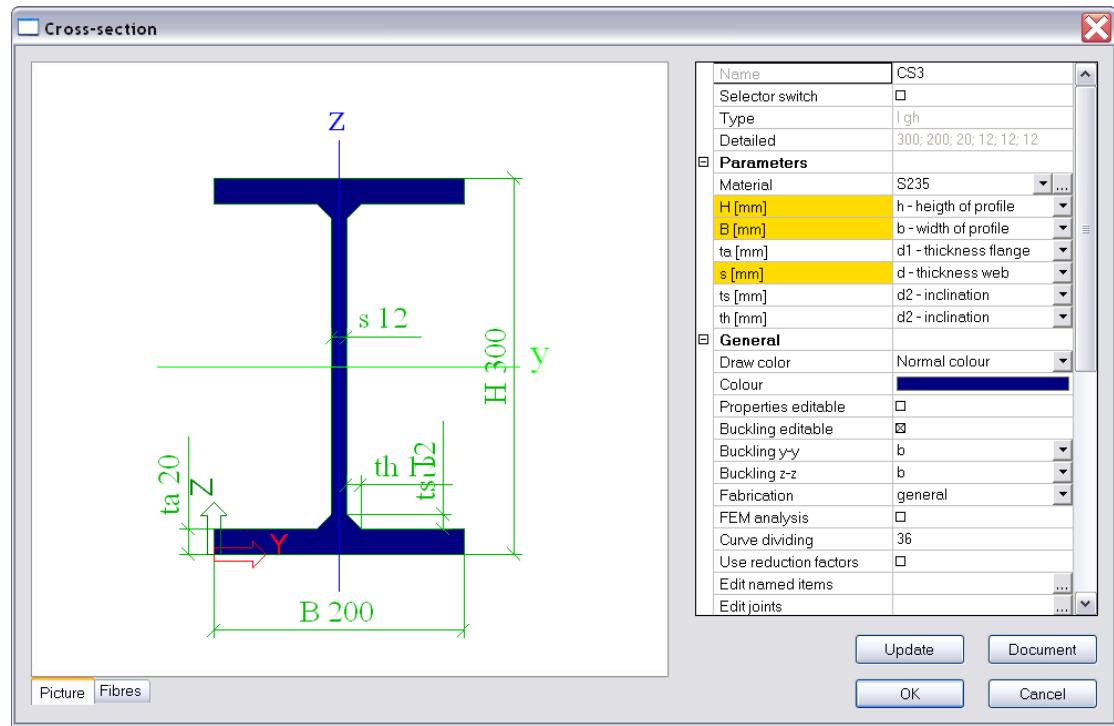
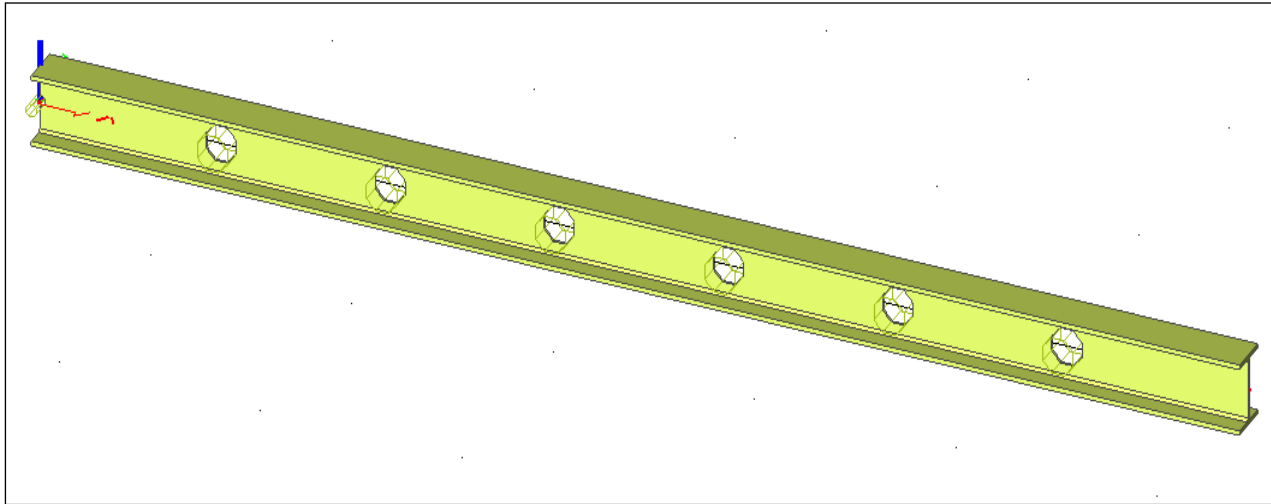

- Project data: - Construction type: General XYZ
- Project level advanced
- Input opening through: 'Structure > 1D member > Modifier > Opening'.

Method

- The following parameters are attributed to the member:

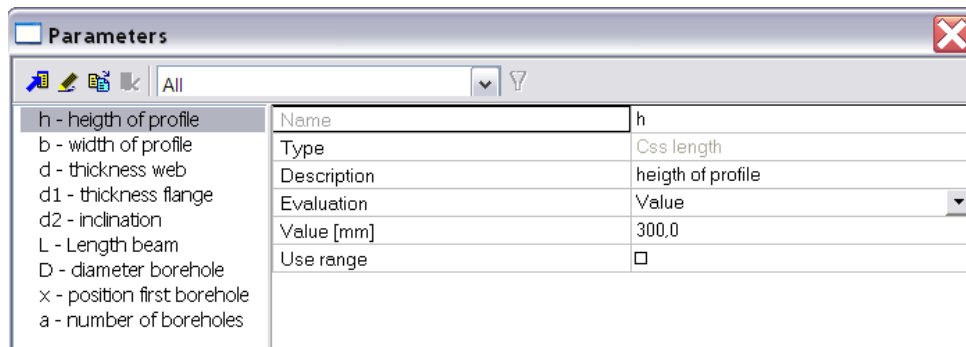

- Height profile h: 300 mm
- Width profile b: 200 mm
- Thickness web d: 12 mm
- Thickness flange d1: 20 mm
- fillet d2: 12 mm
- Length member L: 6 m
- Diameter bore hole D: 150 mm
- Position first bore hole x: 0,15
- Number of bore holes a: 6

- Next, these items are attributed to the structure.
- Subsequently the template settings and template dialog is made.

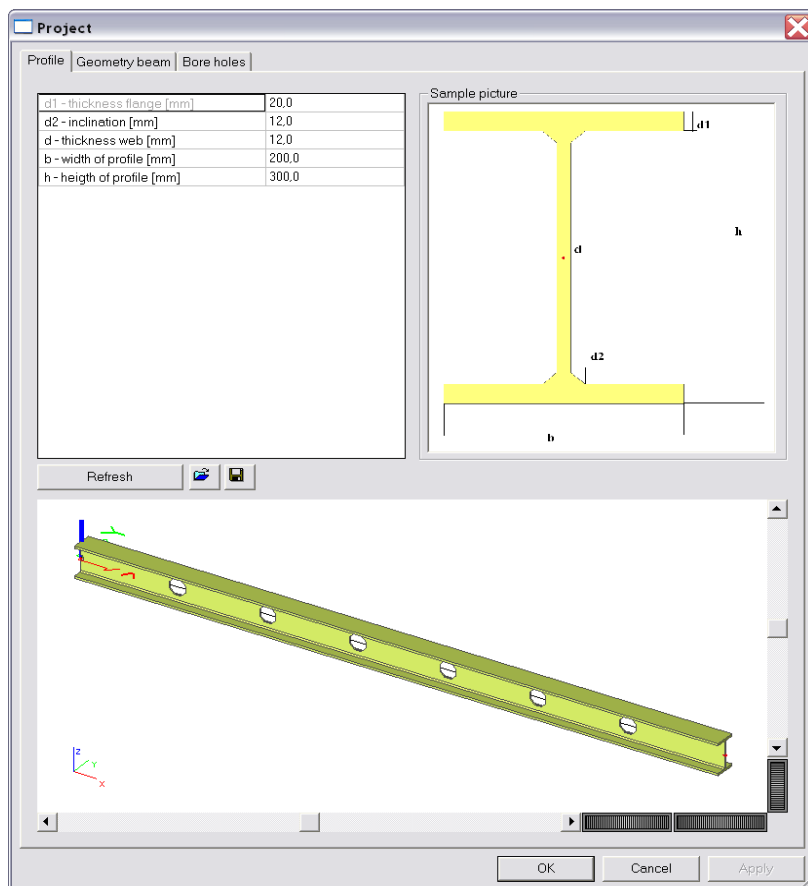

Beam with practical reinforcement

It's also possible to parameterize the reinforcement. This will be shown in following example.

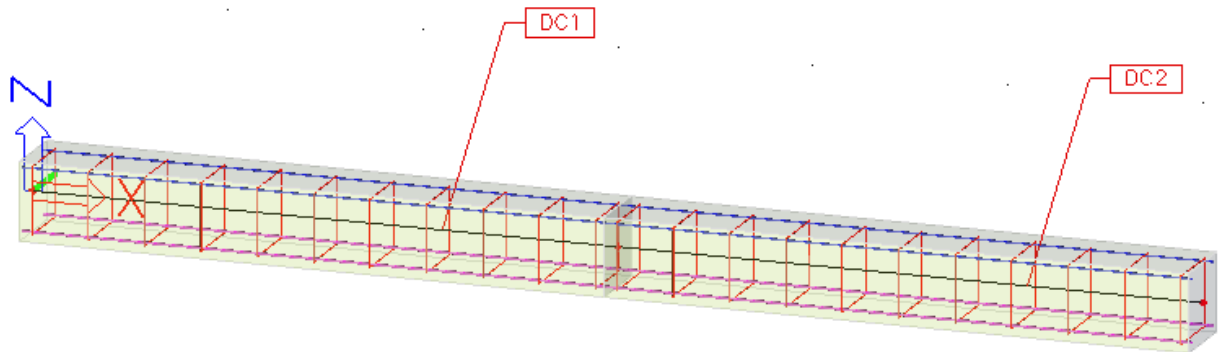

- Project data:
 - Construction type: Frame XZ
 - Project level advanced
- Input through:
 - ☐ Model data
 - ☐ Support
 - ☐ in node
- Load cases:
 - LC1: Selfweight
 - LC2: Variable load: q [kN/m]

- Input practical reinforcement:
 - ☐ Redes (without As)
 - ☐ New reinforcement

Method

- Input of the following parameters with begin value:
 - Height profile H: 400 mm
 - Width profile B: 400 mm
 - Span L1: 3m
 - Span L2: 3m
 - Total span Ltot: L1 + L2
 - Variable line load Q: 15 kN/m
 - Reinforcement diameter above db: 12 mm
 - Reinforcement diameter below do: 16 mm
 - Reinforcement diameter stirrups dstirrup: 8 mm
 - Remark: the reinforcement diameters can only be parameterized when using the practical reinforcement.*
 - Stirrup distance a: 0,3 m

- Group parameters through:

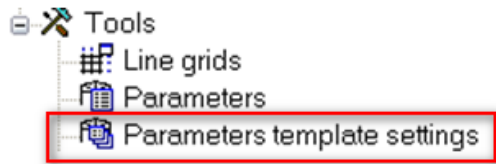

In the dialogue box of the parameter template settings, pictures can be attributed from the gallery:

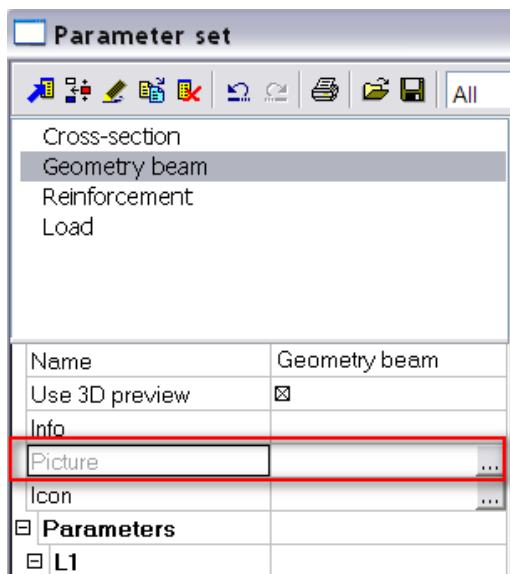

You get the best resolution if you choose the following properties during saving:

- .wmf
- 550 x 550

- Check through Template dialogue

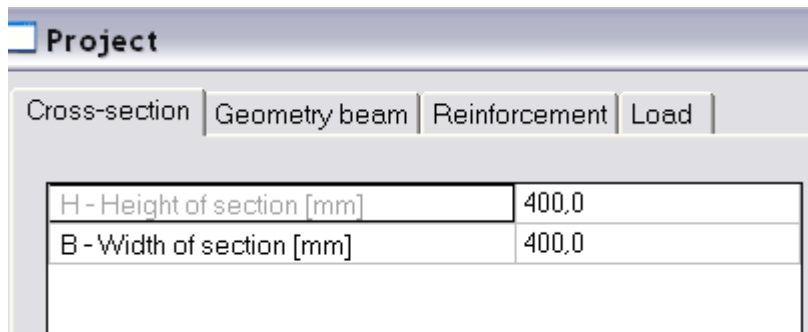

- Afterwards, the entire project can be saved as a template.
This by doing the following: save in the directory 'Esa xx > Templates'
- The project can now be opened as a template and adjusted:

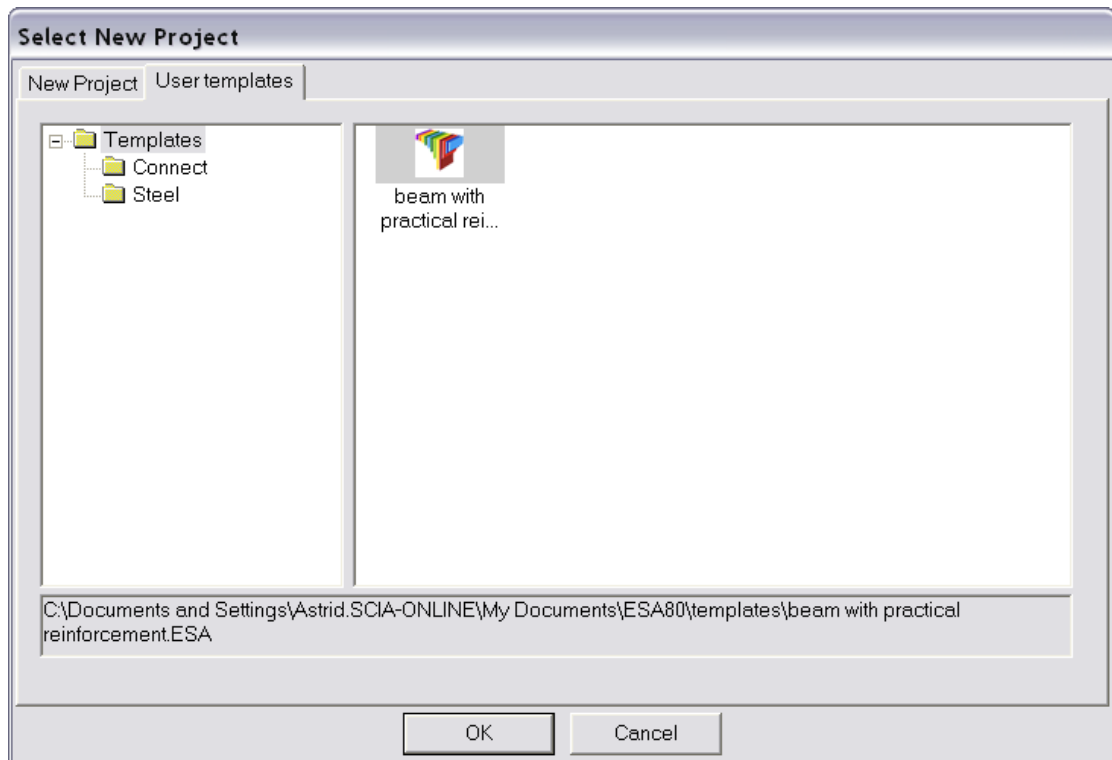

- After opening this template, a dialog box with the entered parameters appears. If desired, particular properties can be adjusted here.

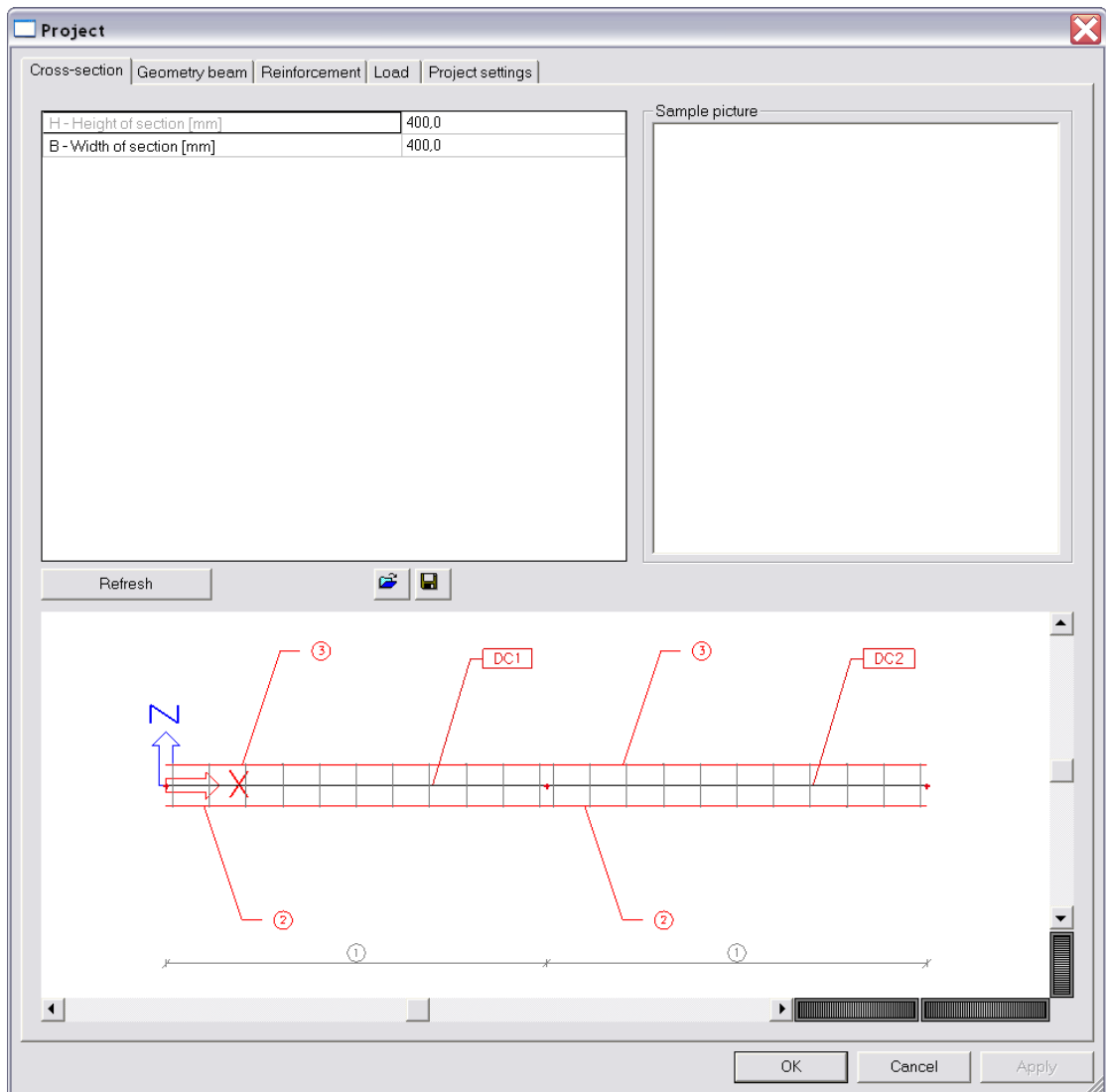

Ground-level

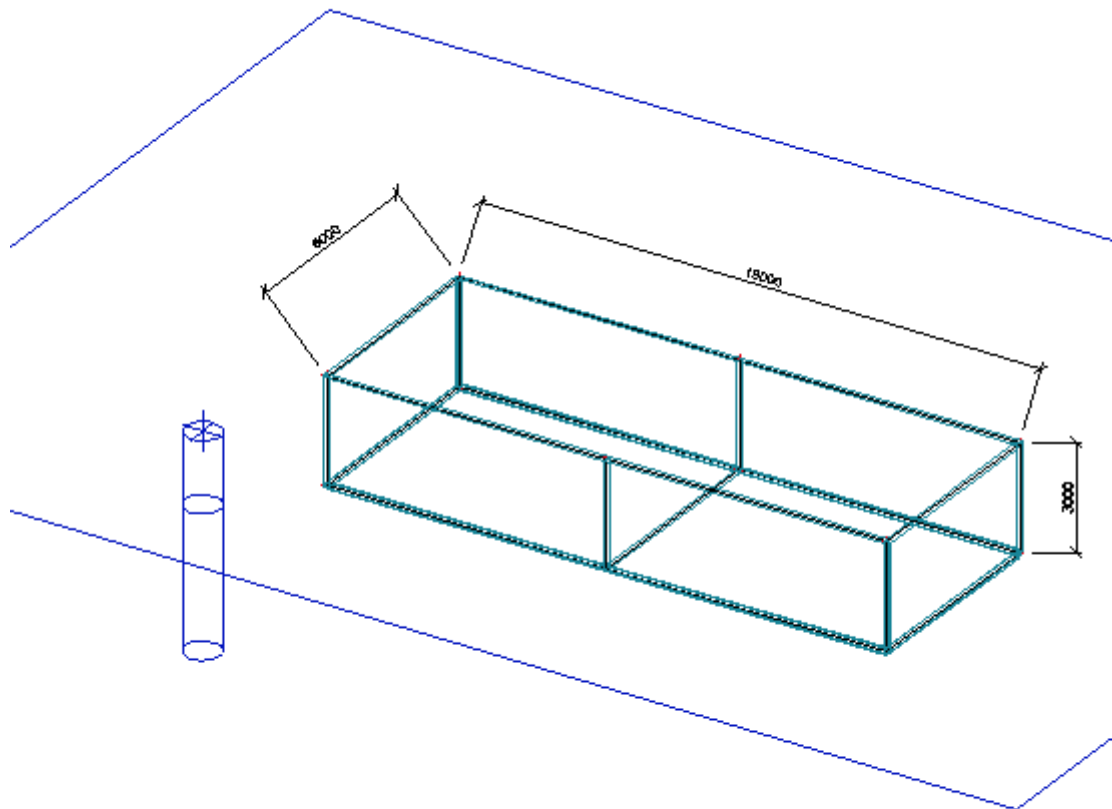
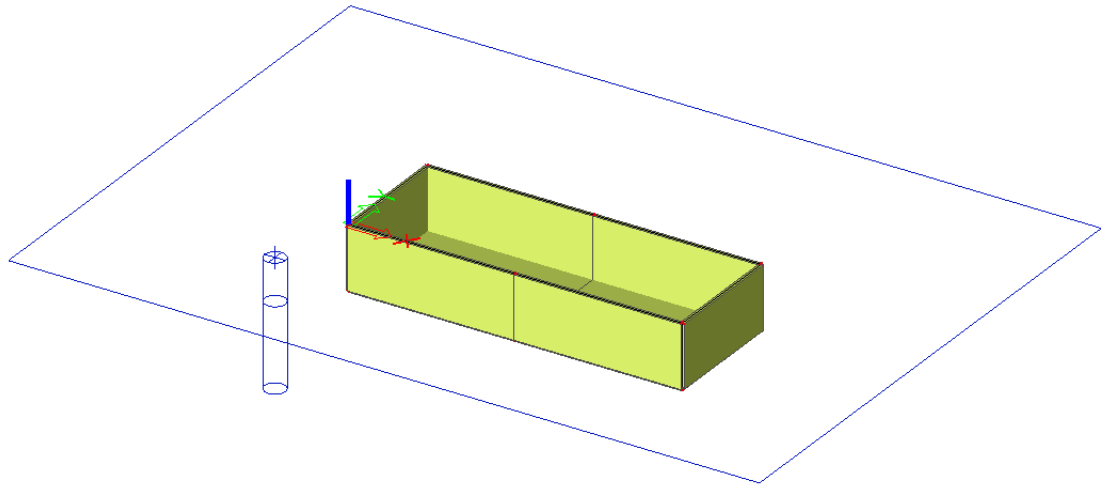

- Project data:
 - Construction type: General XYZ
 - Project level advanced
- Functionalities :
 - Subsoil
 - Soil loads
 - Parameters
- Input support through:
 - Model data
 - Support
 - in node
 - line on 2D member edge
 - surface (el.foundation)
- Input geological profile and subsoil through:
 - Subsoil, foundation
 - Subsoils
 - Geologic profiles

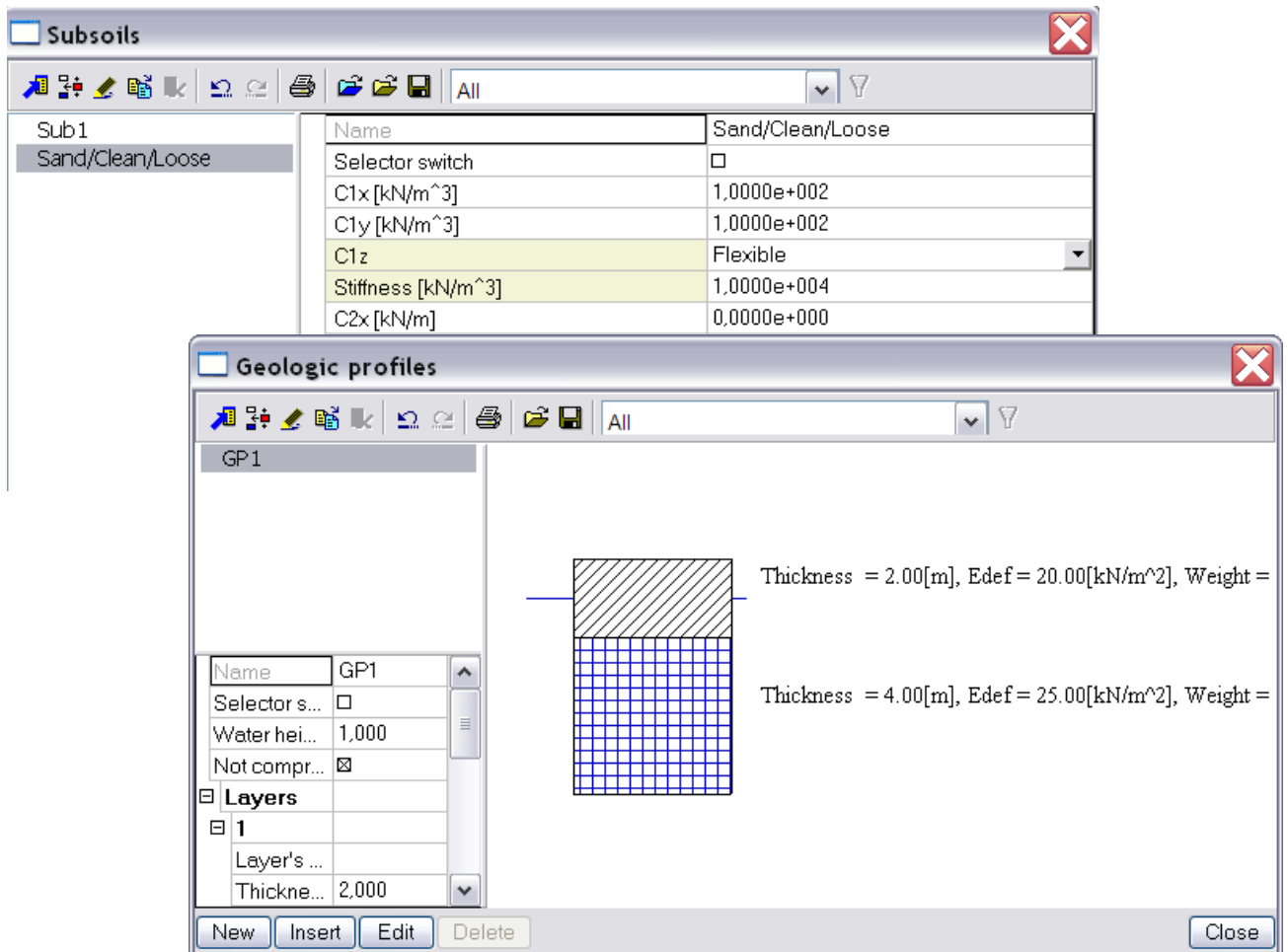

- Load cases:
 - Selfweight
 - Water pressure
 - Soil pressure

Method

- Parameter:
 - Height bore hole profile h: -1 m, restriction between 0 m and -4 m

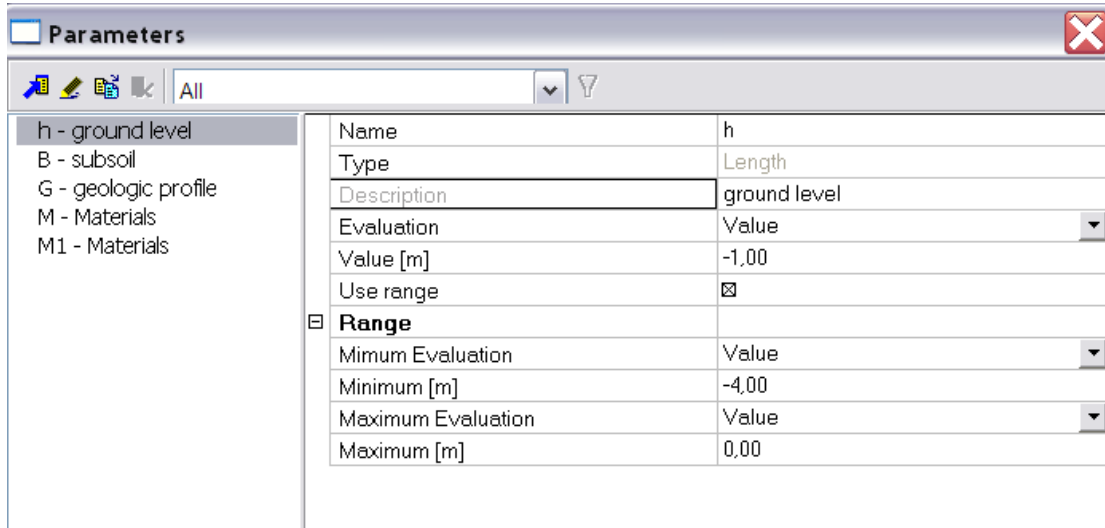

- Test of input data through:

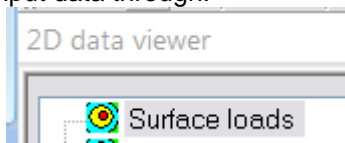

Layers

In this example the number of spans will be varied. This can be done by means of a truc. The basic principle is: every beam belongs to a layer.

Above this a layer has two properties: Activity and Structural type (also Drawing model).

The principle is as follows:

A layer that is not active will not be displayed on the screen.

A layer that has the structural type will not be calculated.

This means that if you put a beam into a layer that is both non-active as in the structural model, it will not be visible and above this, it will not be calculated.

On that way we can make parameters for the properties of the layers.

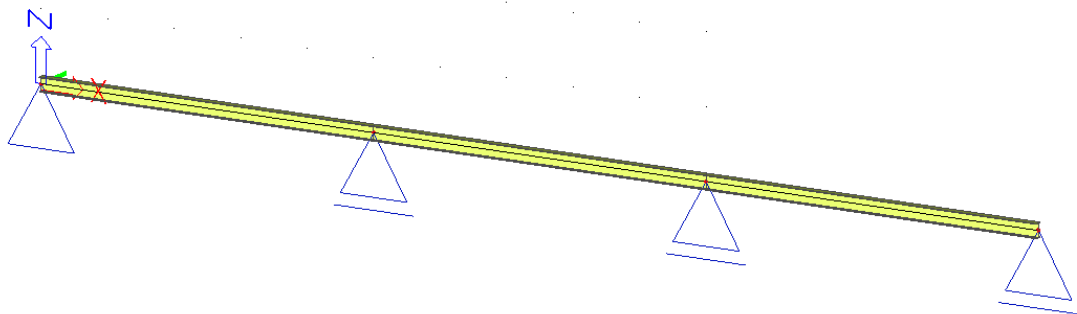

- Project data:
 - Construction type: Frame XZ
 - Project level advanced
- Functionalities - Parameters

- Input support through:
 - Model data
 - Support
 - in node

Method

- The number of members is varied. This is done by means of Parameterizing the activity and the type of model (analysis/structural)
- Input parameters:
 1. Number of members N: 3

Remark:
The maximal number of beams is the number of beams that had been introduced in the project.
 2. Activity of the layers : → Boolean
 - L1: formula $N \geq 1$
 - L2: formula $N \geq 2$
 - L3: formula $N \geq 3$

3. Model type of the layers: → Boolean
- C1: formula not (L1)
 - C2: formula not (L2)
 - C3: formula not (L3)

Example:

N=2:

→ L1 and L2: true, L3 is false

→ C1 and C2: false, C3 is true

This means that Layer 1 and 2 are visible and not in the structural model.

Layer 3 will not be displayed and will be in the drawing model (not in the analysis model).

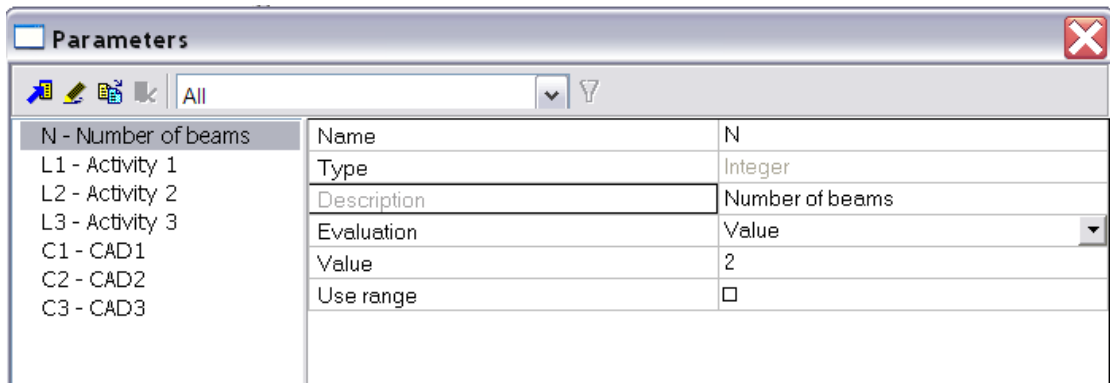

- Grouping the parameters through: Tools > Parameters template settings
- Subsequently a parameter is attributed to the various layers:

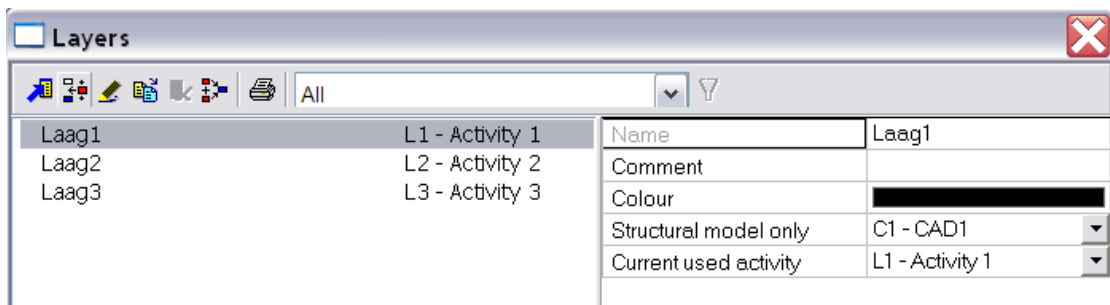
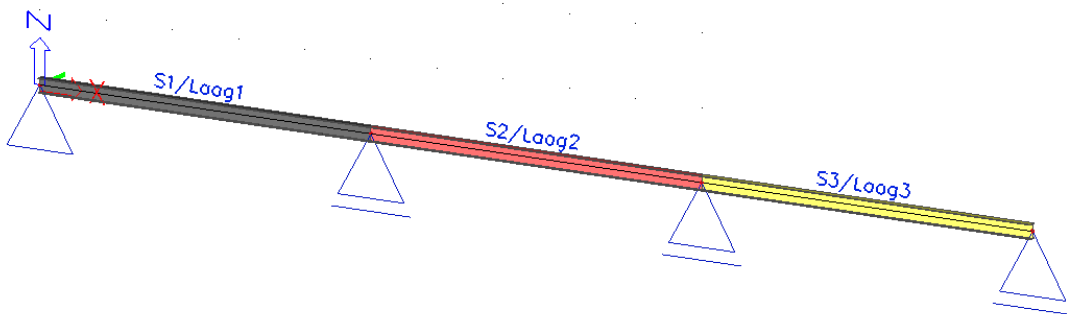

- Variation number of member through the template dialogue
- Use the activity toggle

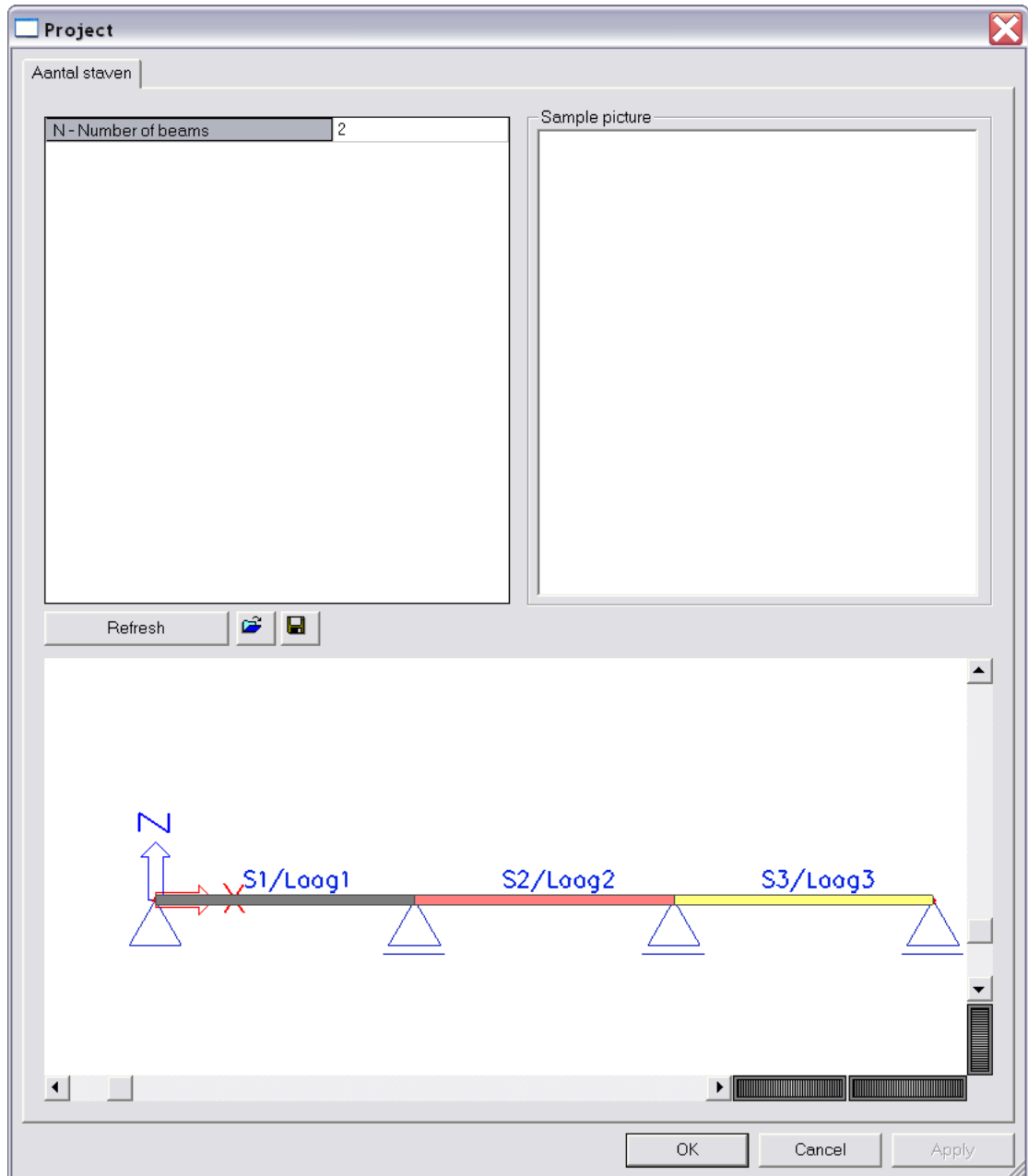

This gives as result:

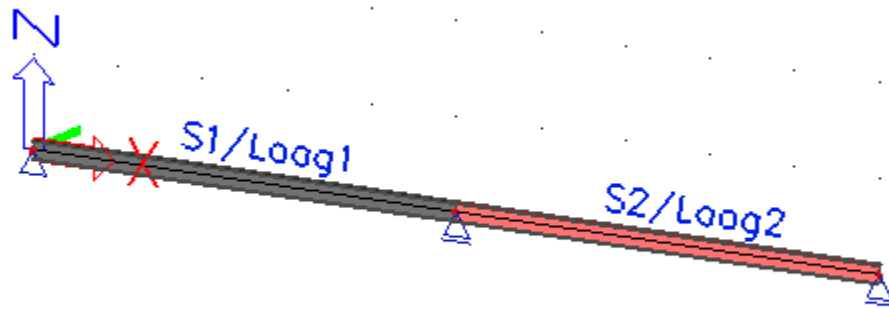

Steel hall

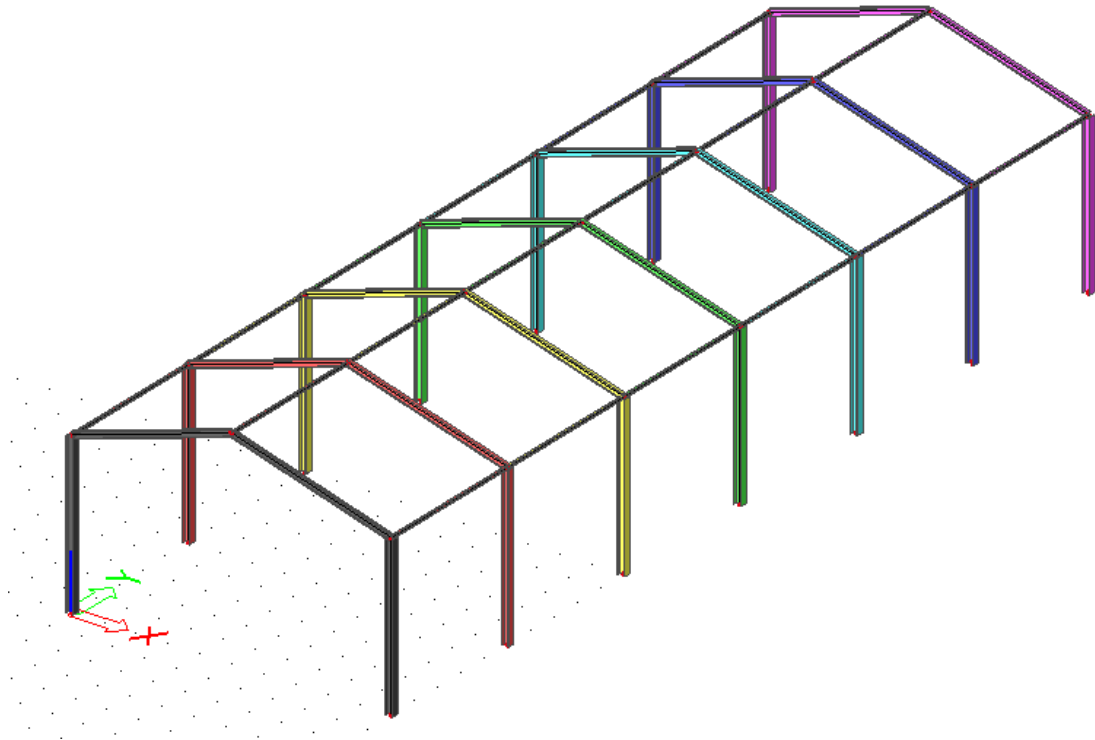

In this example, the number of spans will be parameterized. The same principle with the layers as in the previous example will be used.

- Project data:
 - Construction type: Frame XYZ
 - Project level advanced
- Functionalities - Parameters
- Input support through: Support > nodal support.
- Input catalogue block with parameters H1, H2 and L

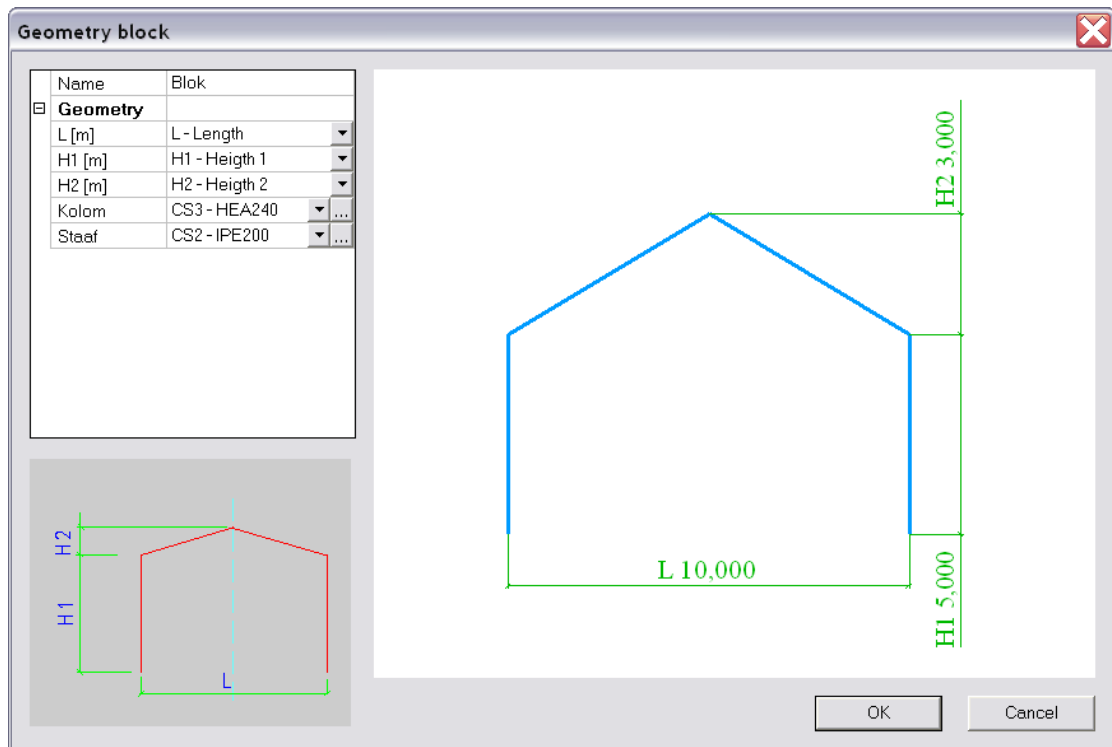

Method

- The number of frames is varied, ranging from 1 up to and including 7, through the binary parameters for the model type and the activity.
- Applying the following parameters:
 - Height H1: 5 m
 - Height H2: 1,5 m
 - Total Height Htot: $H1 + H2$
 - Length L: 10 m
 - Number of frames NS: 7
 - Frame distance S: 5 m
 - Frame distance 1 t/m 5 (S1/5): $S*1 \dots S*5$
 - Total frame distance S6: $S*(NS-1)$
 - Activity layers B1 t/m B7: $NS \geq 1 \dots NS \geq 7$
 - Construction model layers A1 t/m A7: not (B1) ... not (B7)

At which the following parameter types are used:

- Height, length and frame distance : length
- Number of frames: integer
- Activity and type of model layers: boolean

- Now the parameters can be attributed to the properties of the model:
 - Layers

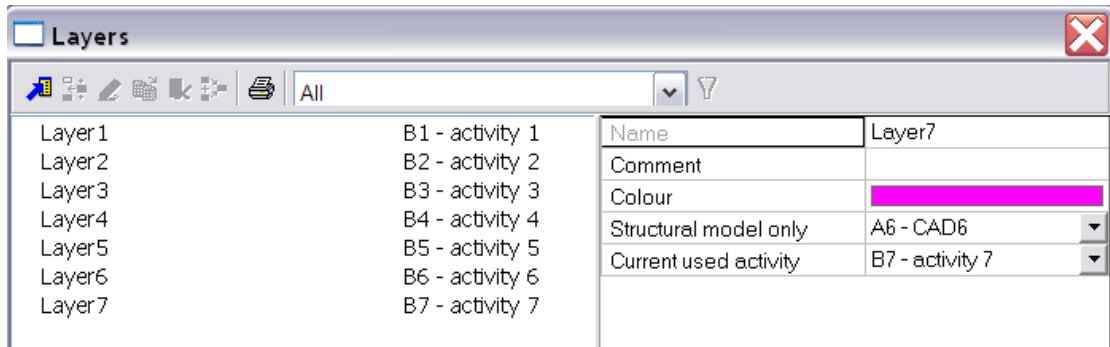

- Geometry properties of the catalogue block
- Coordinate Y of the nodes of the model: parameter frame distance

Plate with ribs

Two types of parameterized plate with ribs are shown here. The previous principle of the properties of the layers is used here.

Plate with ribs_1.esa

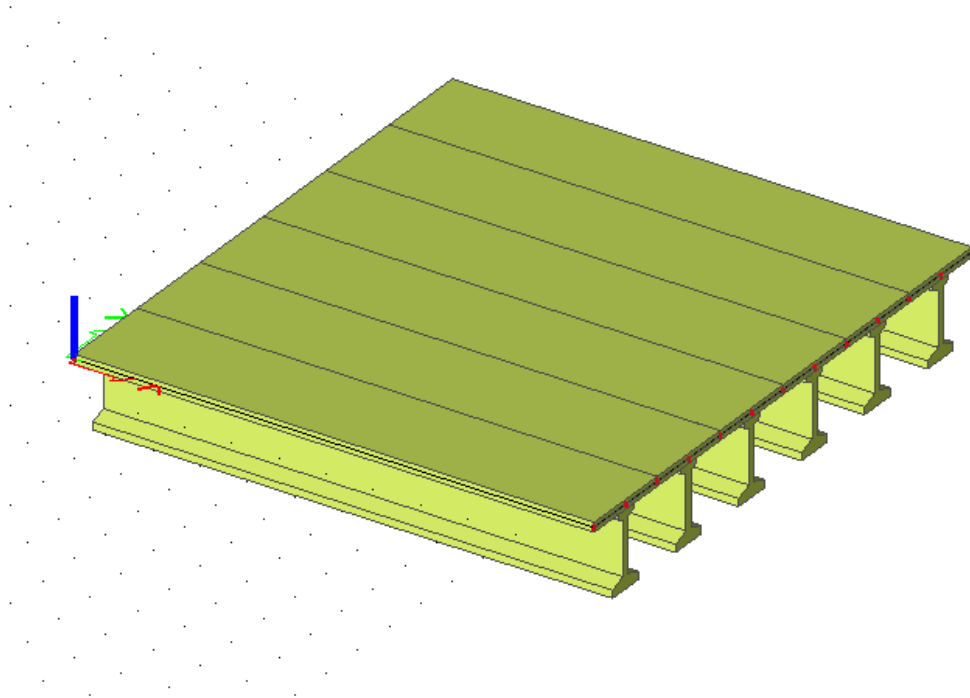

- In the first case the number of ribs is dependent on the width of the plate. The offset of the ribs and the distance between several ribs remains the same in each case.
- To obtain this, we divide the plate into several parts. The number of the parts is equal to the maximal number of ribs.
- In this case we the maximal number of ribs is 6.
So, a parameter N with type 'integer' is made with standard value 6.
- Other parameters are:
A1...A6: Boolean
Formula: $N \geq 1 \dots 6$

C1...C6: Boolean
Formula: $\text{not}(A1 \dots A6)$
- Afterwards, these parameters can be attributed to the properties of the 6 created layers:

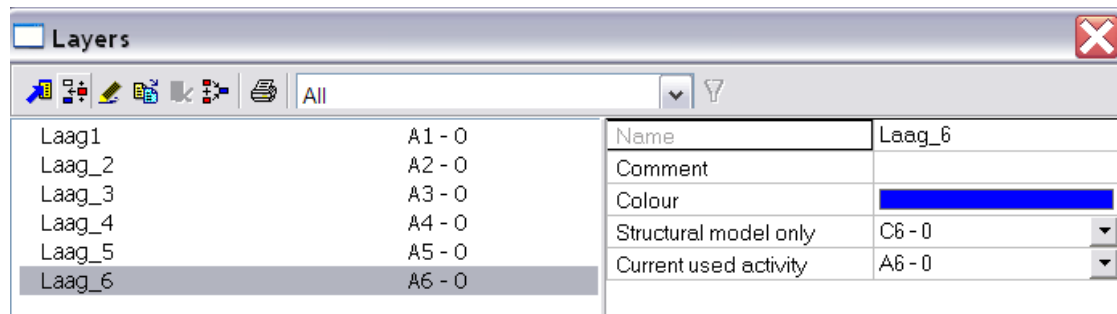

The plate with the connected rib can now be input in the respective layer.
In the 'view parameters for all', the colour can be set on 'colour by layer'.
This is practical to verify if each rib is in the correct layer:

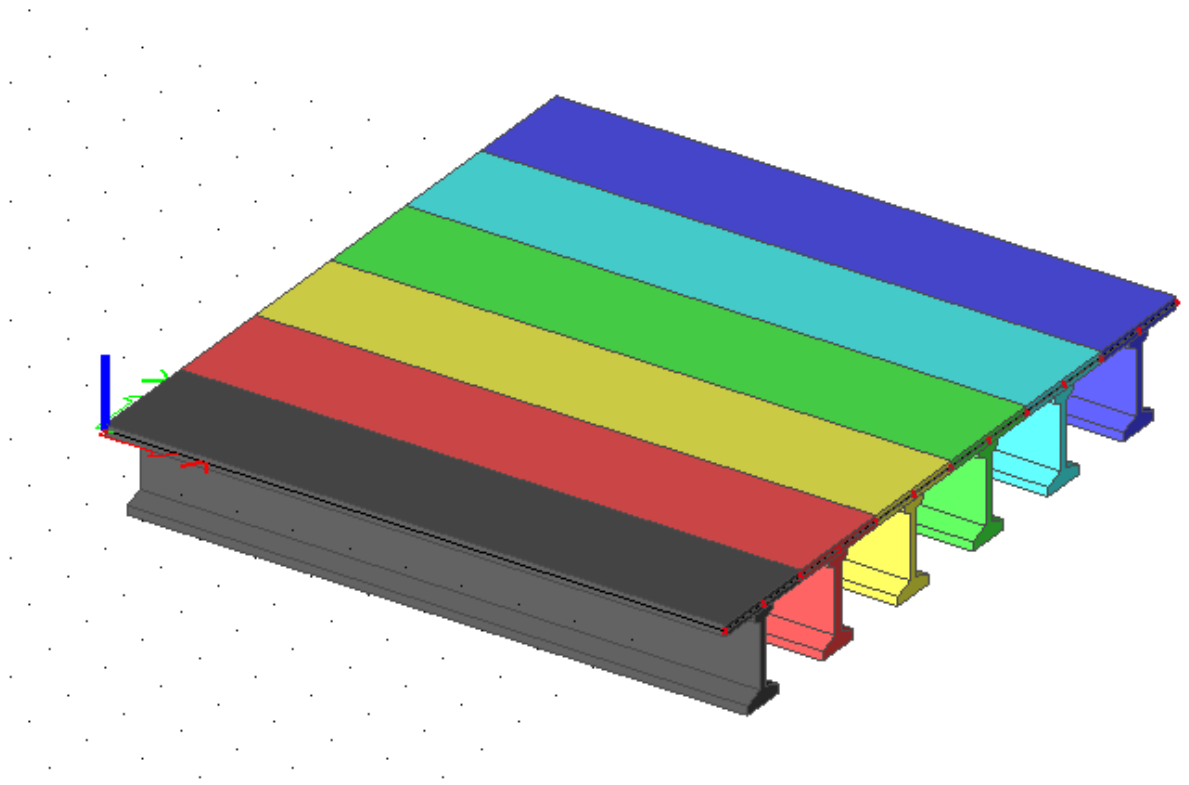

- After creating a group in the 'parameters template settings', the number of ribs can be adapted in the Template dialogue:

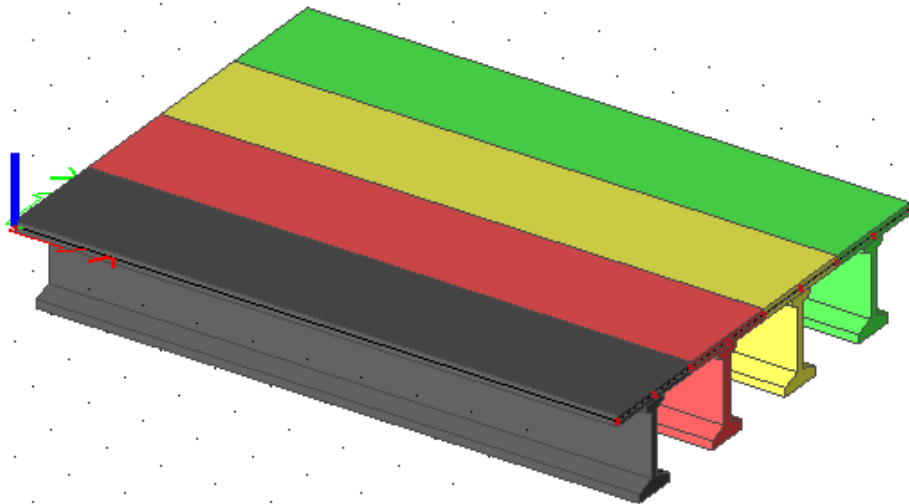

Plate with ribs_2.esa

In this case, the offset between the outer ribs and the end of the plate remain constant. The distance between the inner ribs is always regular.

This is shown in the understanding example.

Originally, a plate with 5 ribs is created. Afterwards, the ribs are input in layers and the x-coordinates are parameterized.

- First of all the parameter for the number of ribs is created:
This can be an integer value between the range of 2 to 5.

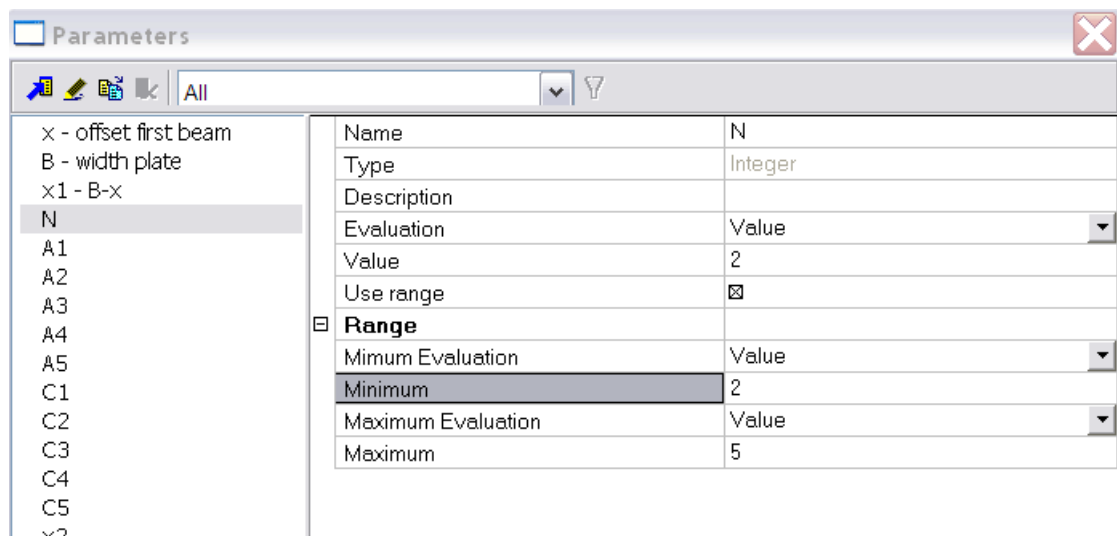

- The offset coordinates of the outer ribs are:
 - x for the first ribs
 - B- x for the last rib, with B the parameter for the width of the plate
- The 3 inner ribs get the following coordinates:
 - $x_2 = x + ((B-2x)/(N-1))$
 - $x_3 = x_2 + ((B-2x)/(N-1))$
 - $x_4 = x_3 + ((B-2x)/(N-1))$
- As in the previous examples, parameters A1..A5 and C1..C5 are created for the properties of the layers
- To finish this, the ribs are attributed to the correct layers.

- When changing the number N in the template dialogue, we get the following results:

- N = 2

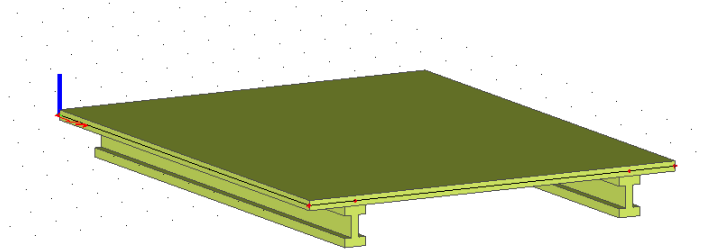

- N = 3

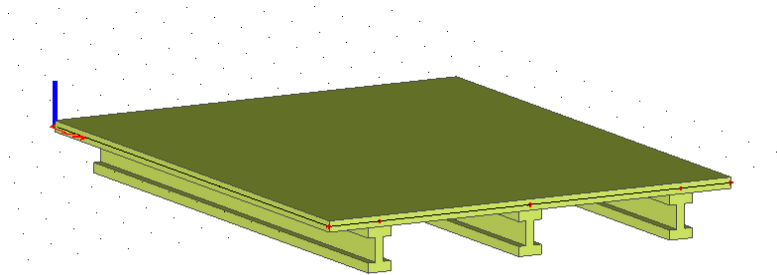

- N = 4

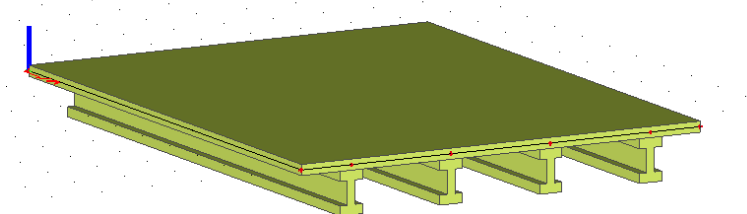

- N = 5

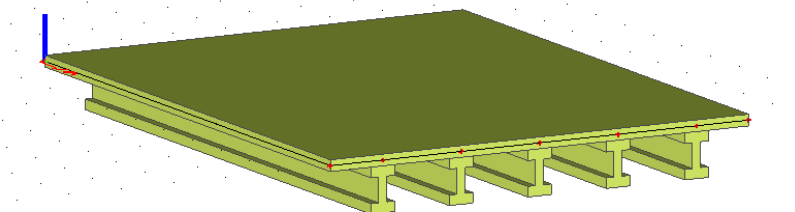

Tubular plates

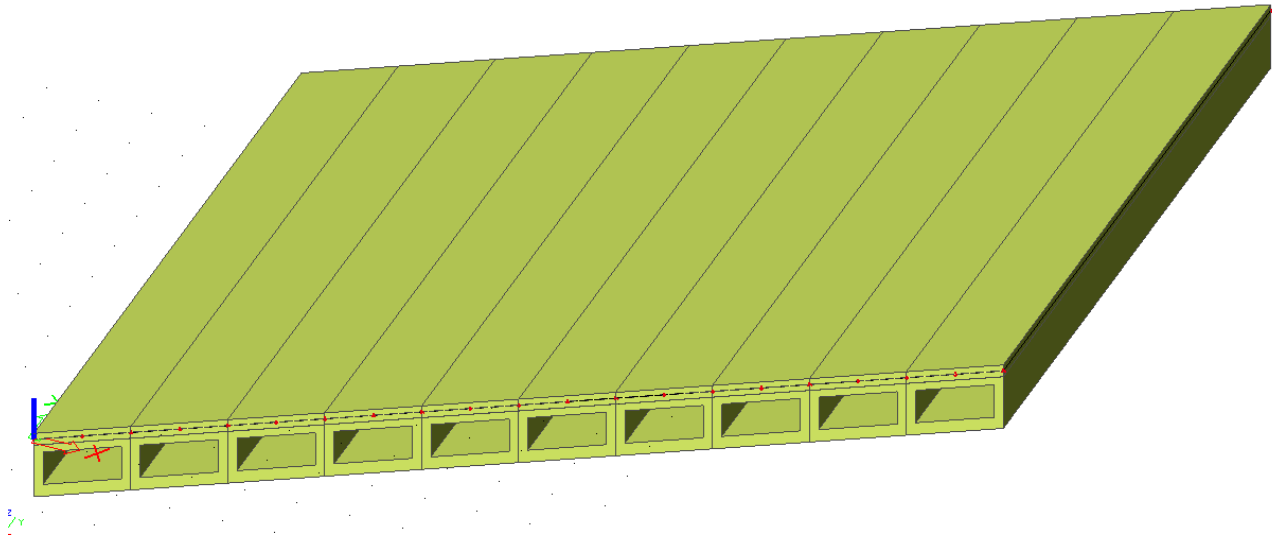

- Project data:
 - Construction type: General XYZ
 - Project level advanced
- Functionalities – Parameters
- Input channels as ribs: Plate rib

Method

- The principle is as follows:
 - The plate is divided into different subplates. The reason for this is if the plate will shorten, also a rib will disappear. By making different little plates, this can be solved.
- Making the parameters that determine the geometry properties of the plate and rib:
 - width profile b : 1480 mm
 - height profile h : 1100 mm
 - height upper flange h_1 : 250 mm
 - height lower flange h_2 : 160 mm
 - thickness web t : 140 mm
 - thickness plate d : $=h_1$
 - length partial panel: $=b$
 - angle of fillet plate α : 30°
 - total length plate L_{tot} : 12 m

- These parameters are attributed to the channel

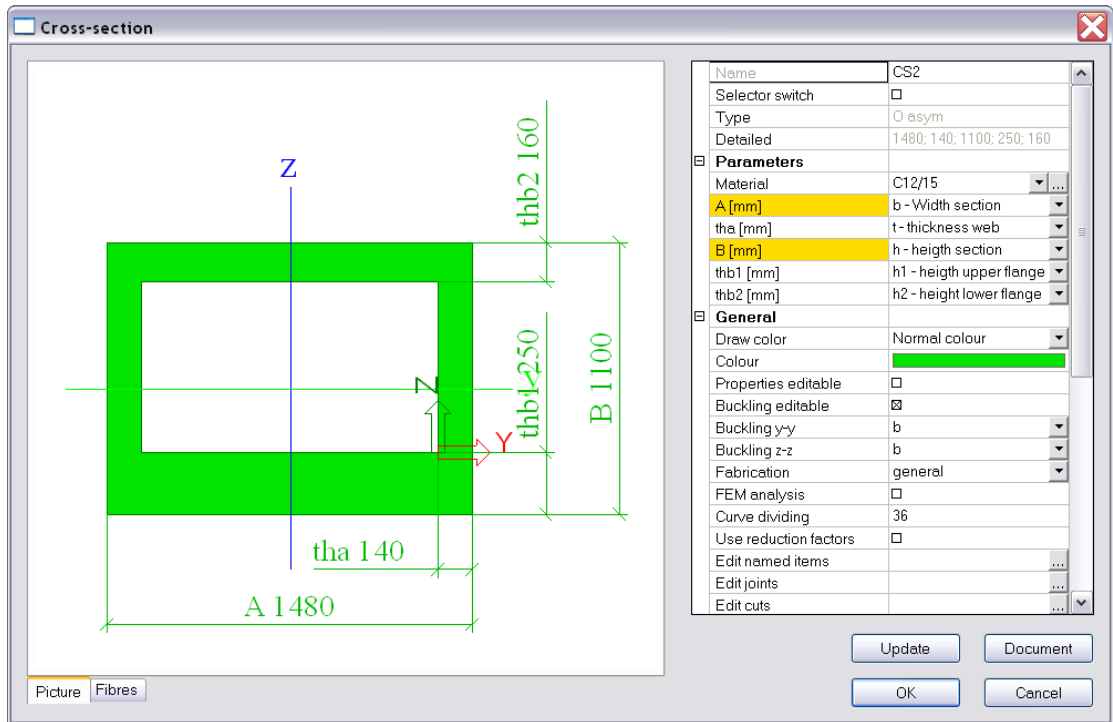

- Input of 1 plate (as an element of the whole plate)
- Input of the plate rib with effective width b

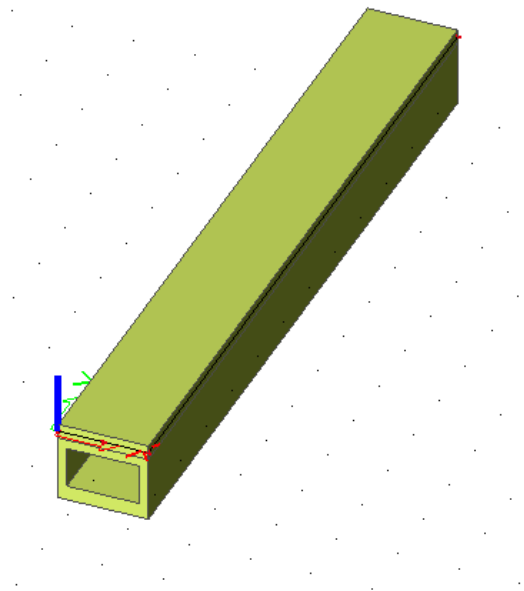

- Use of dummy members, e.g. circular profile with diameter 5mm so the rib and member can be connected by a common node. Without these dummy beams, the ribs will not follow the plate after changing the dimensions of the plate.
- Connect nodes/edges to members! 

- Input other plates through “more copies”: 

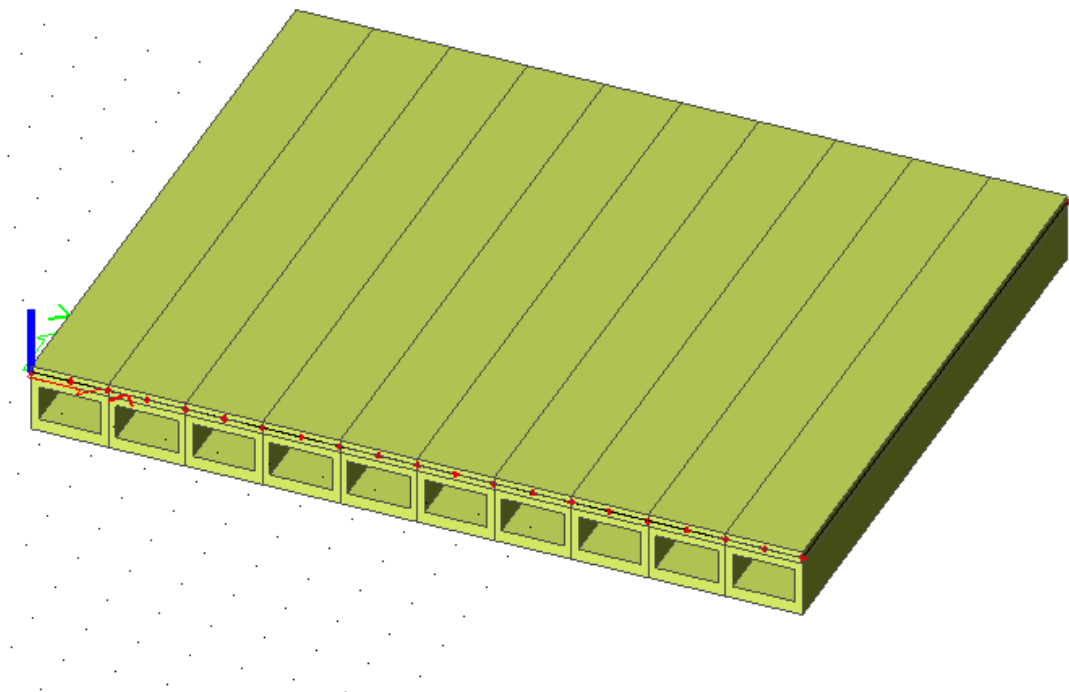
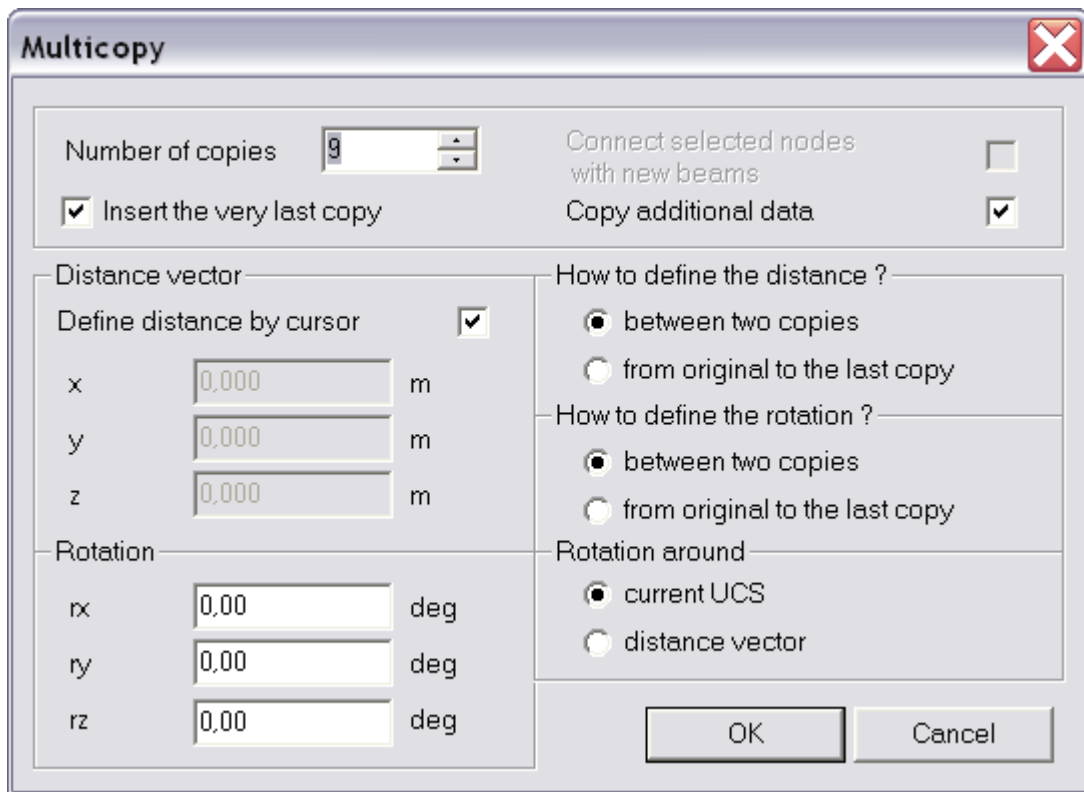

- An angle alpha of 30° is entered as parameter. With this, the x- and y-coordinates of the vertices of the partial plates can be entered:

Example:

Partial plate 6:

- x-coordinate $x_6 = b \cdot 6$
- y-coordinate $y_{6a} = \tan(\alpha) \cdot x_6$
- y-coordinate $y_{6b} = \tan(\alpha) \cdot x_6 + L_{tot}$

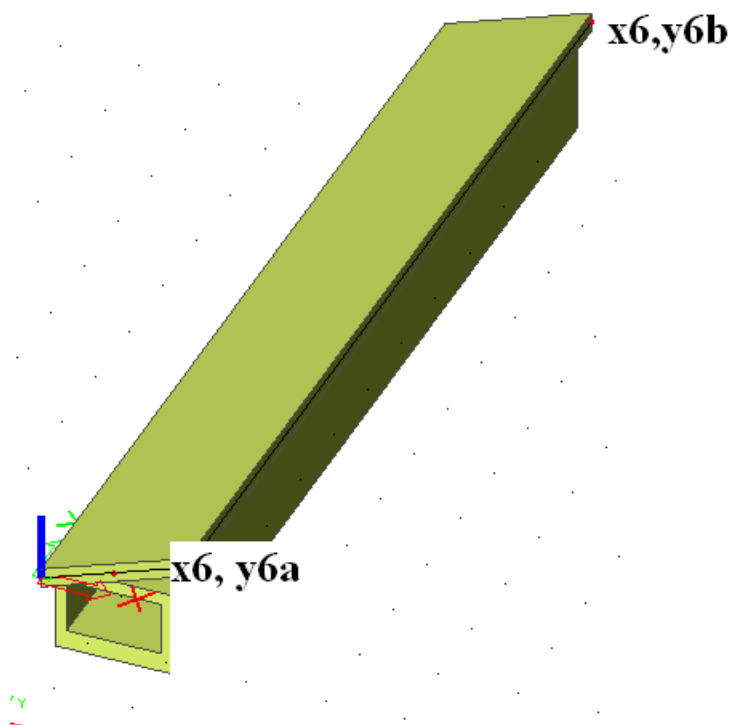

This way, an inclined plate is obtained.

- Adjusting the number of partial plates/ribs:
 - Parameter for the number of parts: $N (< = 10)$
 - Parameter $L1..10$: They determine the activity of the various layers
Vb. $L6$: boolean with formula $N \geq 6$
 - Parameter $C1..10$: they determine the type of model of the various layers
Vb. $C6$: boolean with formula $\text{not}(L6)$
- Making the different parameter template and adjusting the number of parts to e.g. 6 through the template dialog:

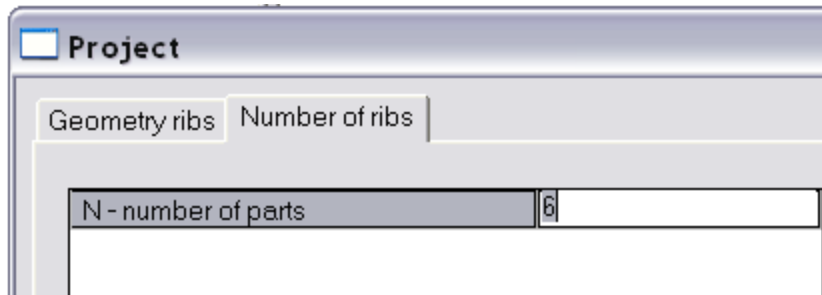

→ Analysis model:

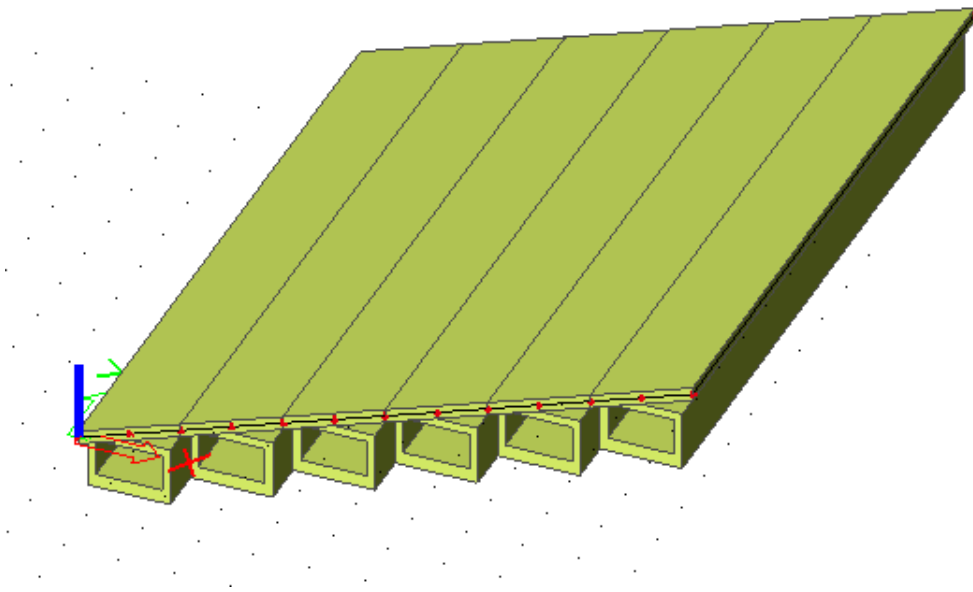

→ Structural model

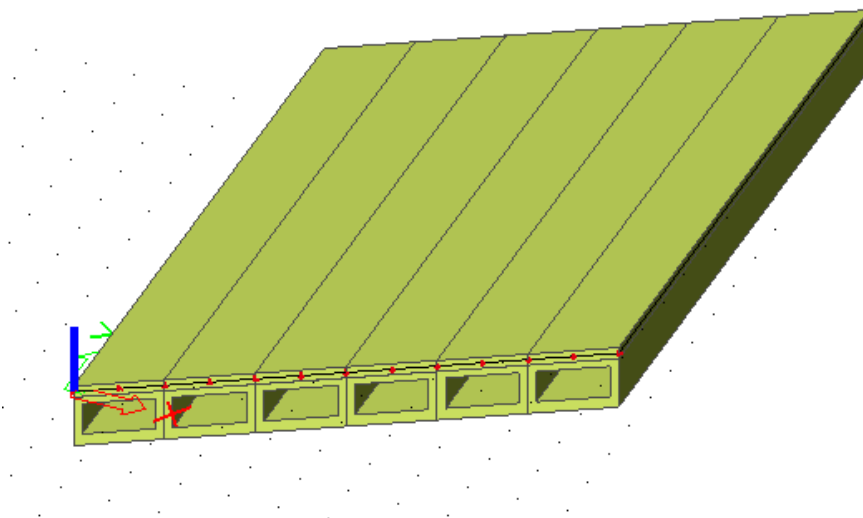

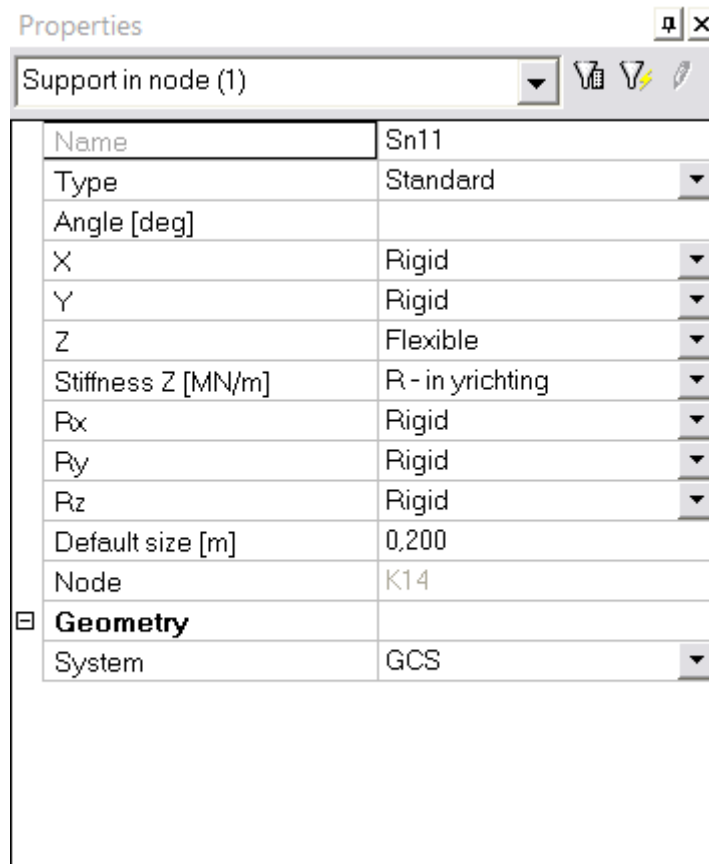
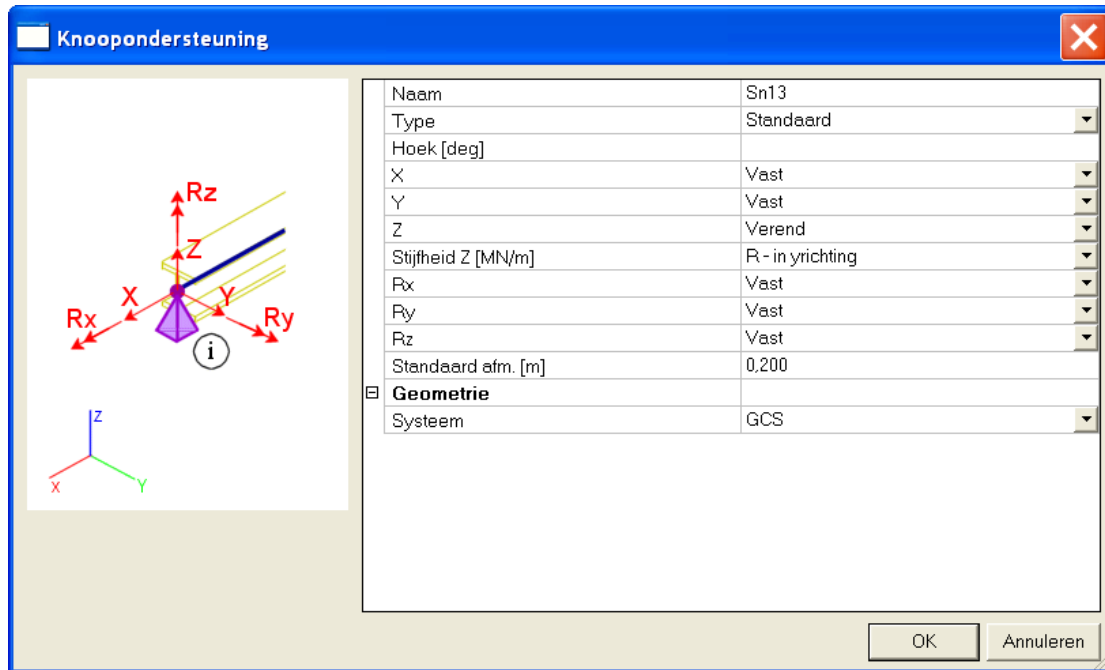

Hollow core slab

A practical use of parameters is in the case of hollow core slabs.
In this example several functionalities are applied:

- prestress
- building stages
- TDA
- Parameters

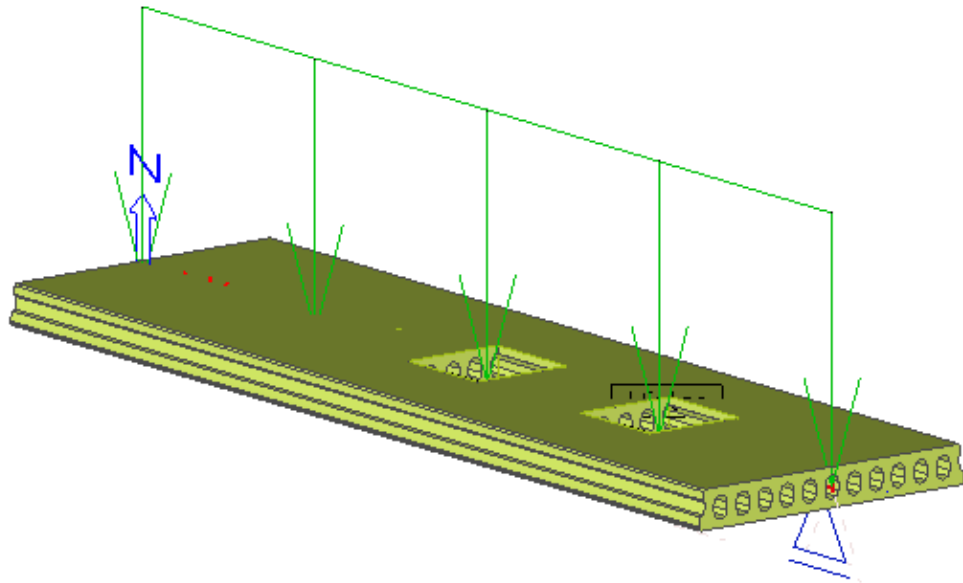

- Project data:
 - Construction type: Frame XZ
 - Project level advanced
- Functionalities
 - Parameters
 - Concrete: fire resistance
 - Prestress:
 - Advanced
 - Hollow core slab
- Model: Construction stages
- Span: 6.2 m
- Material type: concrete C25/30
- The hollow core slab is entered by means of a dwg

Method

1. Entering a cross-section

The outline and the opening are selected alternately, after which they can be imported through 'import selection'.

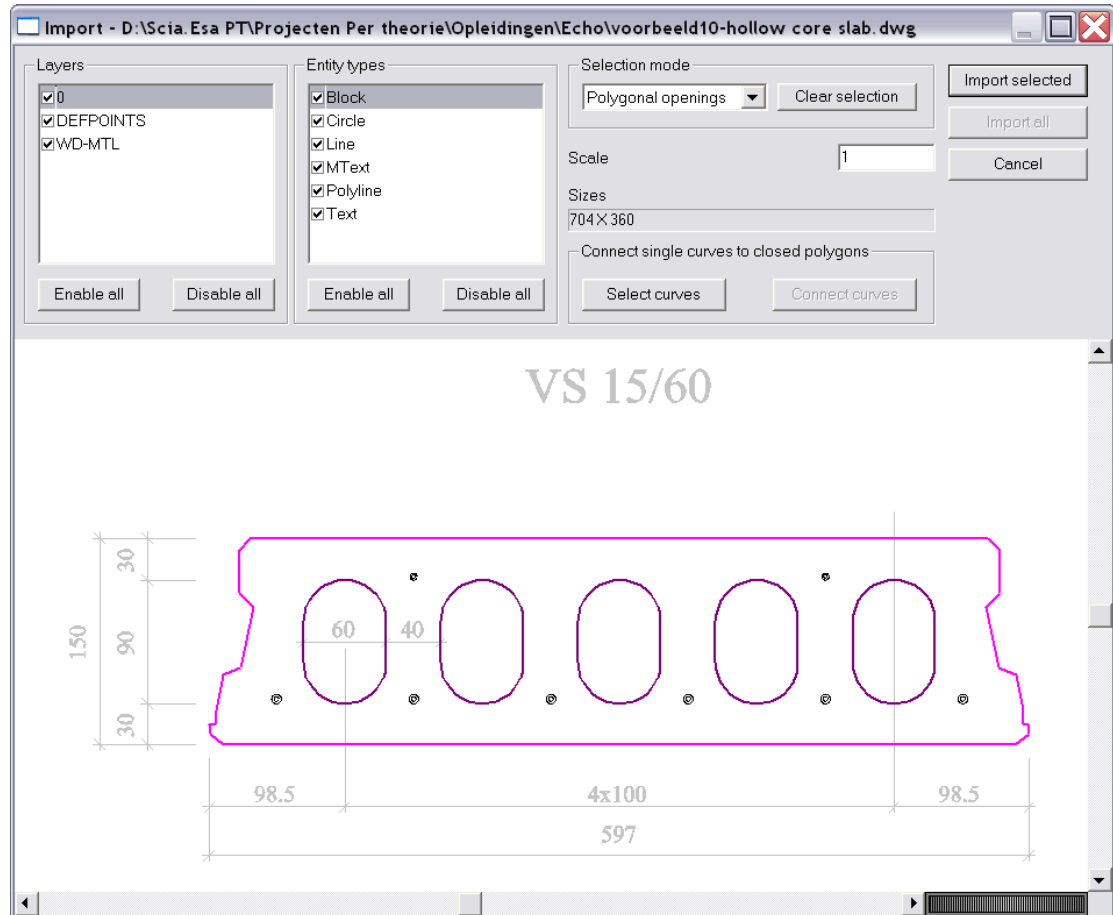

2. Inserting the prestressed tendons

Subsequently the prestressed tendons are entered:

Go to the concrete menu > Prestress – strand pattern:

2 regions are now made for the bore hole pattern.

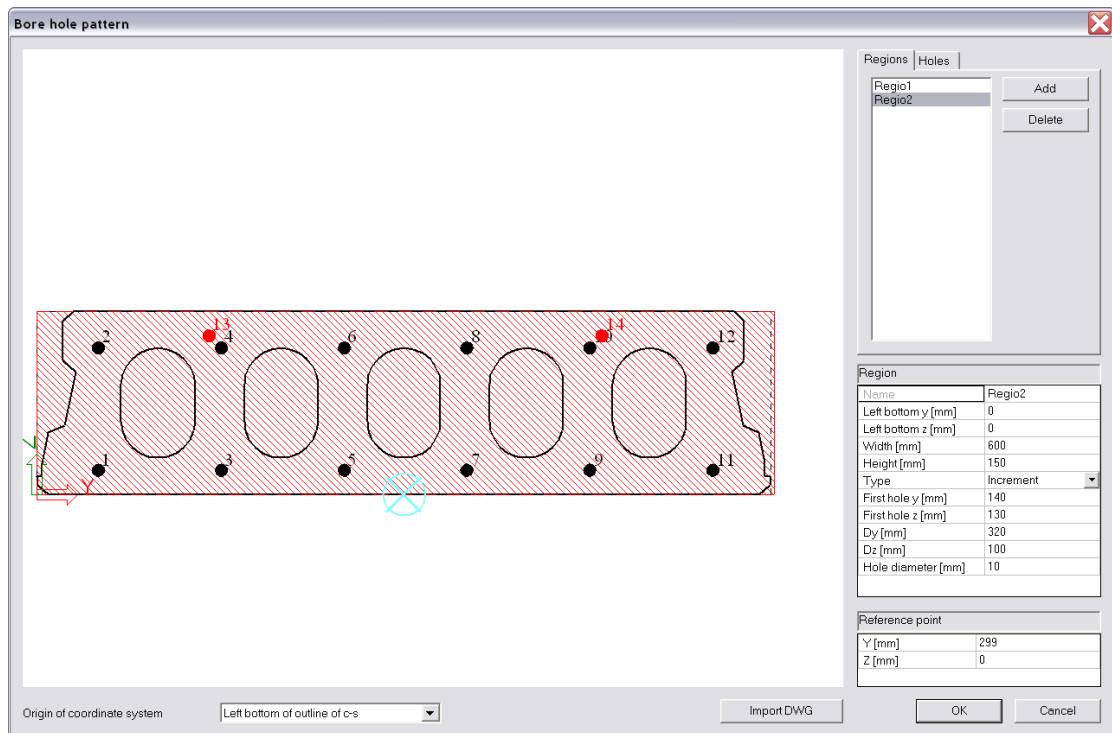
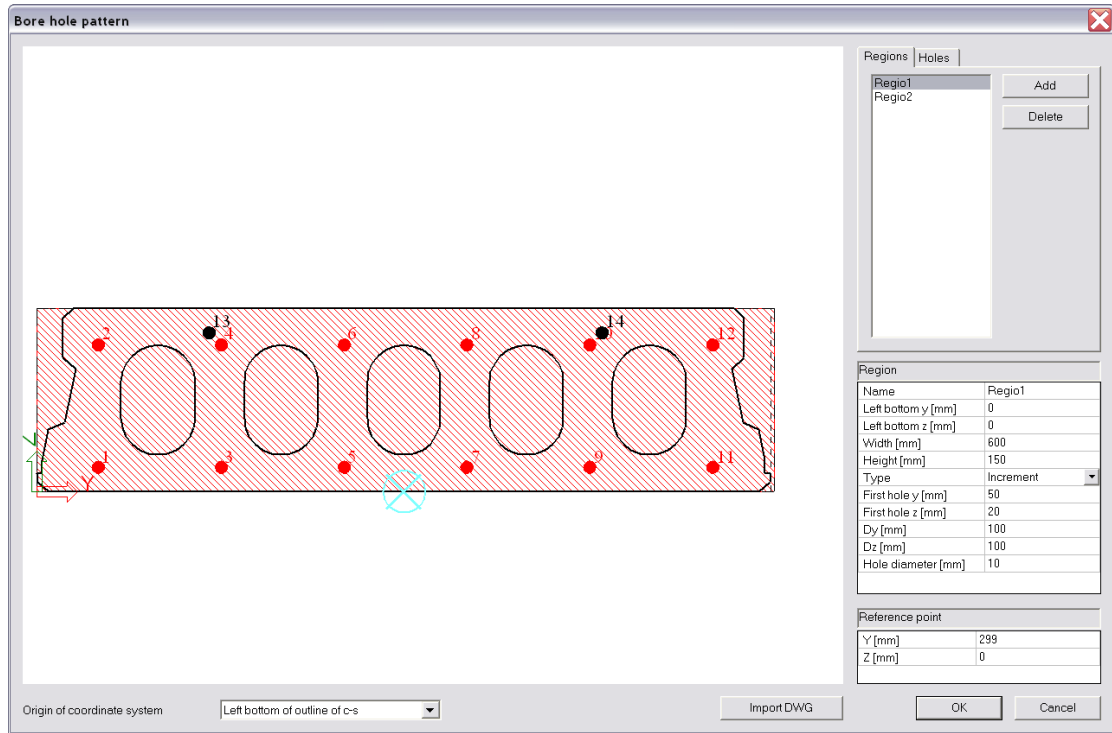

The initial stress of the prestressed tendons is 1250 Mpa.

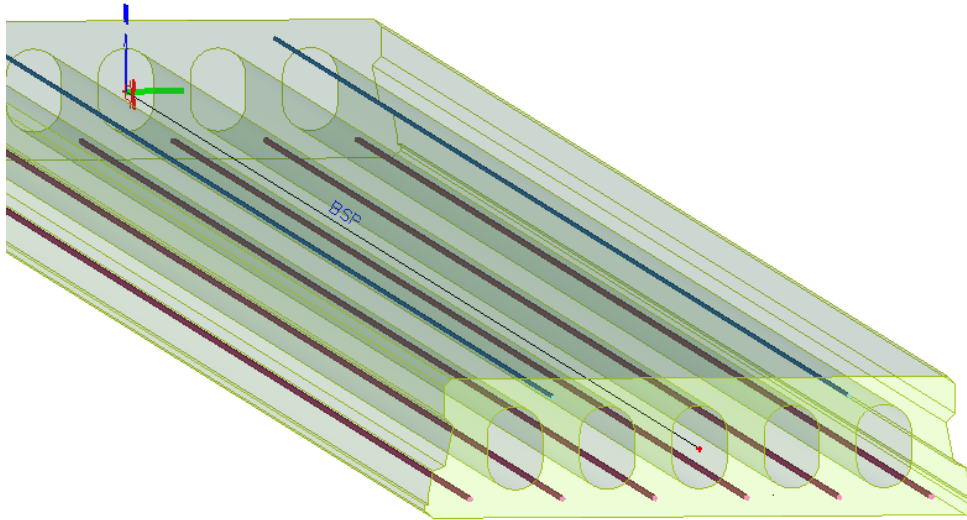

3. Inserting the supports

- point load on node, at begin and end node of the member
- point load on member: on 0,07 and 6,13 m
- point load on member: on 0,8 and 5,4 m

4. Making the load cases

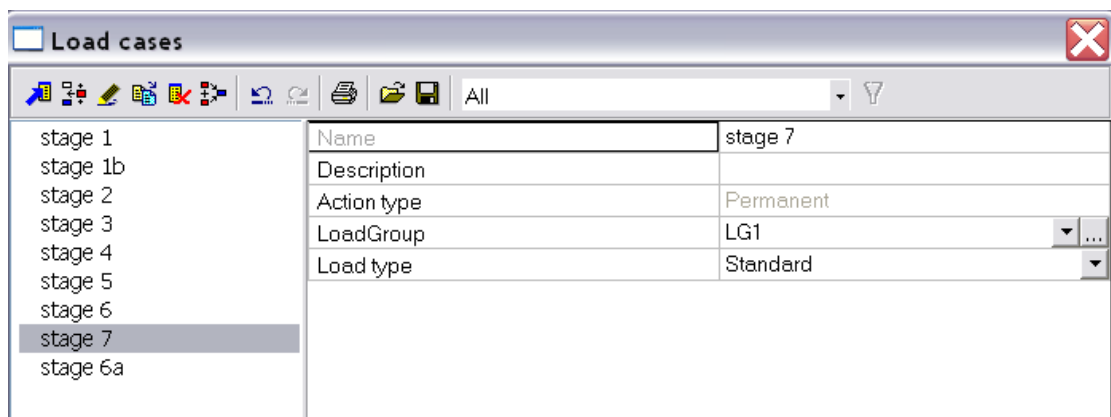

- Selfweight member
- Prestress 1250 Mpa
- Stage 2: empty (permanent)
- Stage 3: empty (permanent)
- Stage 4: line load on member 0,6 kN/m (permanent)

- Stage 5: line load on member 1,2 kN/m (permanent)
- Stage 6: line load on member 1,2 kN/m (variable – long term)
- Stage 7: empty (permanent)

5. Inserting the construction stages

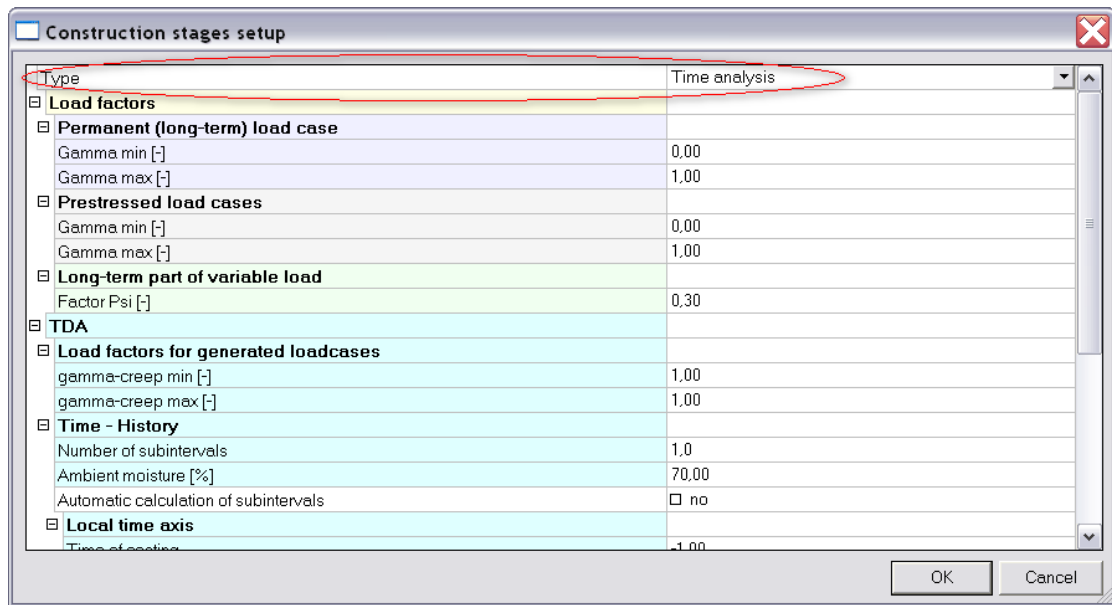

Stage 1

Prestress and selfweight of the member

Load cases: prestress + selfweight

Time: day 1

Relative humidity: 100%

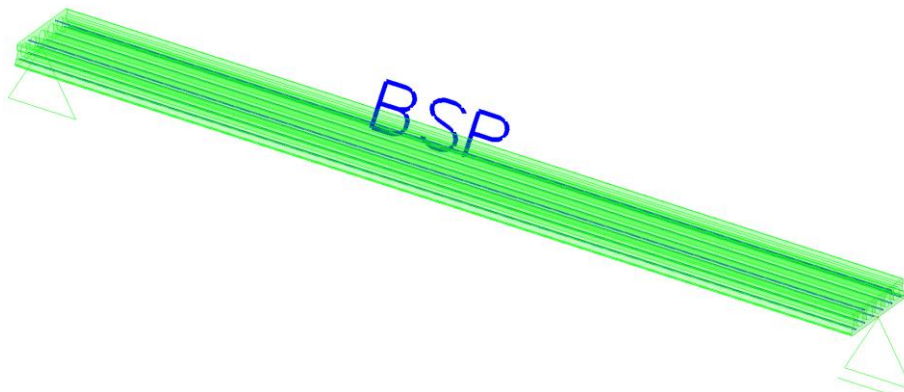

Stage 2

Transport

Load cases: empty
Time: day 1,1
Relative humidity: 100%

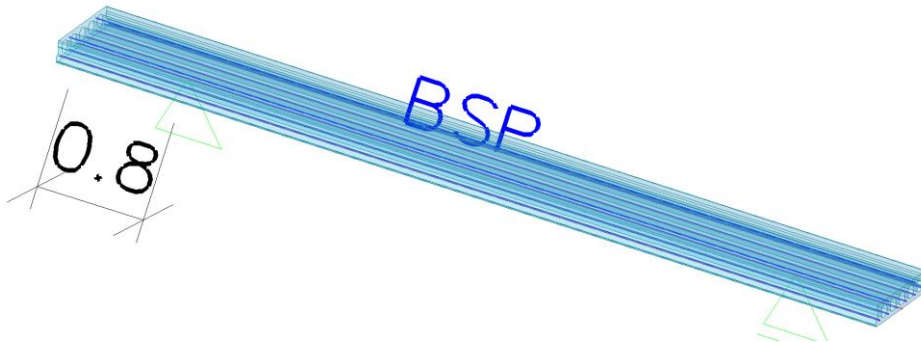

Stage 3
Storage

Load cases: empty 2
Time: day 1,2
Relative humidity: 70%

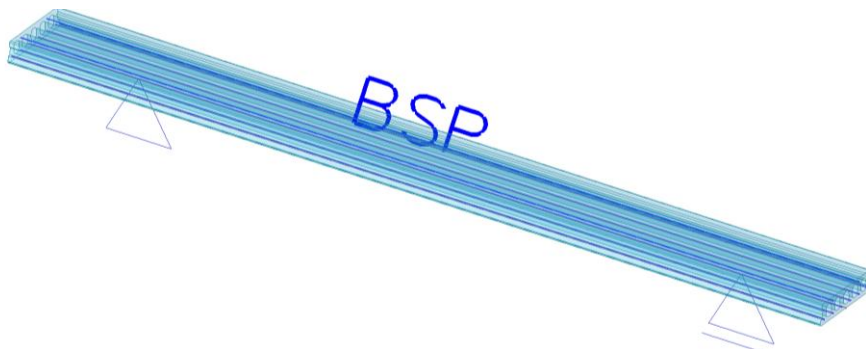

Stage 4
In situ, placing the plate

Load cases: q wall 0,6 kN/m
Time: day 28
Relative humidity: 70%

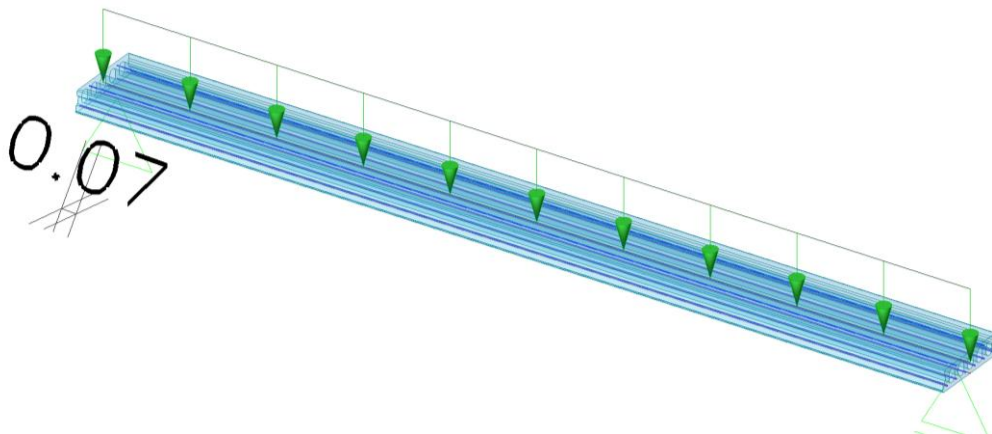

Stage 5

Casting of the coating

Load cases: 1.2 kN/m
 Time: day 50
 Relative humidity: 70%

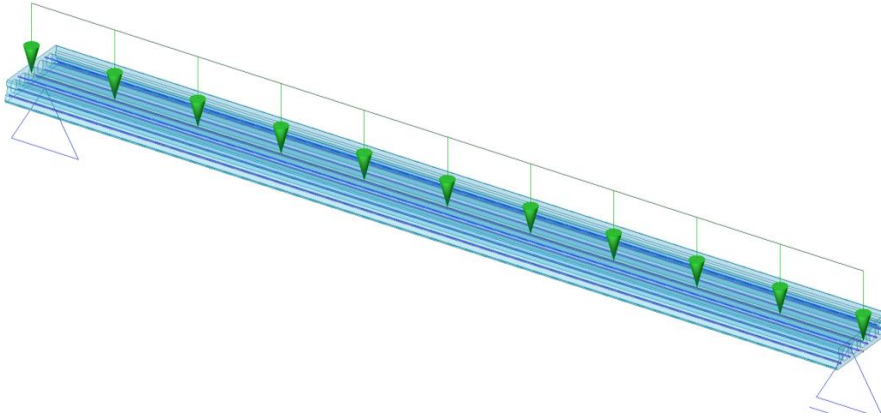

Construction stages

ST1	Name	ST5
ST2	Order of stage	5
ST3	Description	
ST4	Global time [day]	T5 - fase 5
ST5	Number of subintervals	1
ST6	Ambient humidity	RV1 - RV 2
ST7	Last construction stage	<input checked="" type="checkbox"/>
	<input checked="" type="checkbox"/> Load case permanent or long te...	
	Load case	fase 5
	Gamma min [-]	0,00
	Gamma max [-]	1,00
	<input checked="" type="checkbox"/> Load case prestress	
	Load case	None
	Type of generated combinations	Code independent

Actions
 Variable load cases >>>

New Insert Edit Delete Close

Stage 6
 Service

Load cases: long termVar 1.2 kN/m → will be used as long term load. Here it is important to pay attention to the duration of the load case, sc 'long'.

Time: day 100
 Relative humidity: 70%

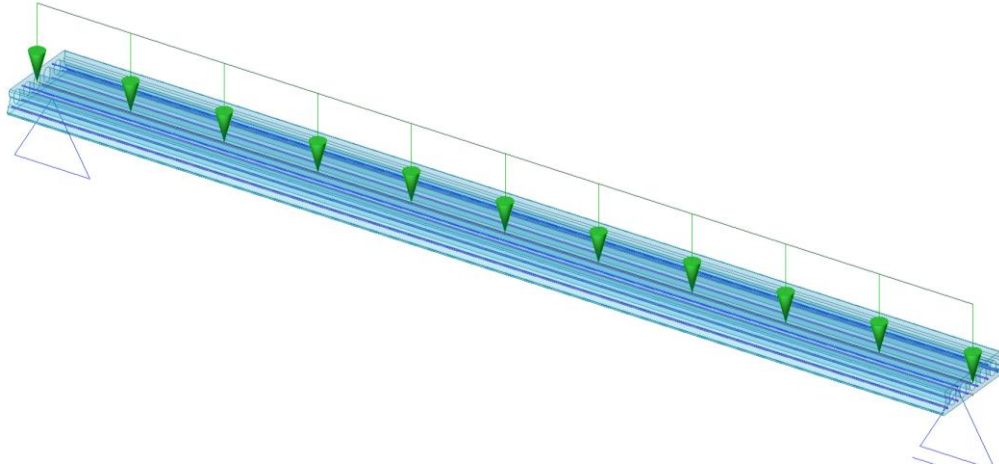

Stage 7

After 50 years

Loads

Load cases: empty3

Time: day 18000

Relative humidity: 70%

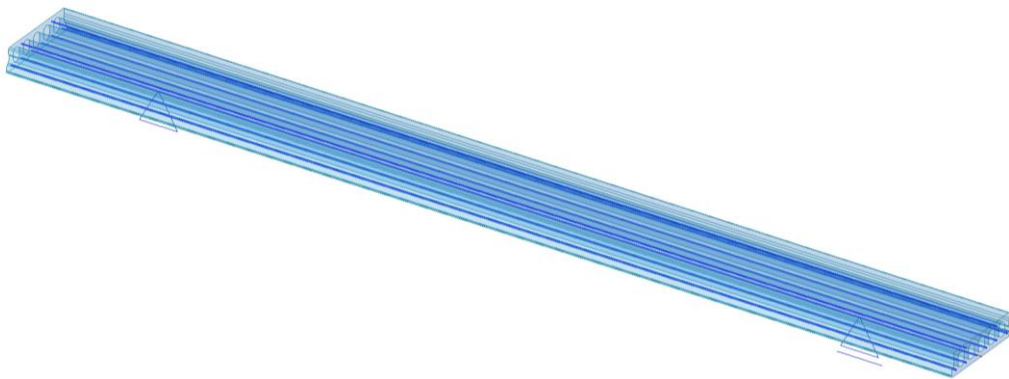

6. Inserting the parameters

- **Length hollow core slab:**

Type: length

Evaluation: value: 5,25 m

- **Height hollow core slab:**

Type: cross-section length

Evaluation: value: 150 mm

- **Location support on member:**

Type: length

Evaluation: formula: resp. Length member – 0,07 and length member – 0,8

- **Parameters general cross-section:**

Type: cross-section length

Evaluation: value

(examples: width to first opening, width opening, width between the openings,...)

- **Initial stress:**

Type: stress

Evaluation: 1200 Mpa

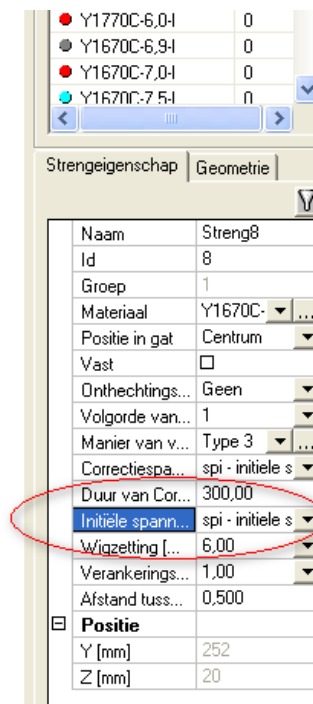
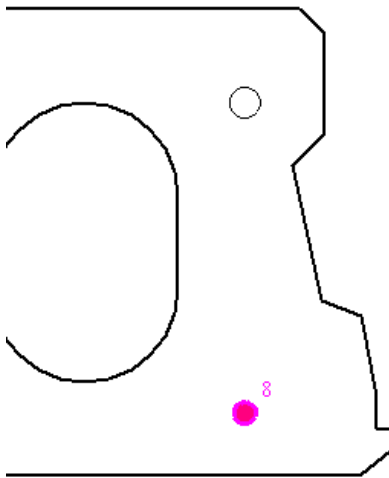

- **Anchorage length:**

Type: length

Value: 1m

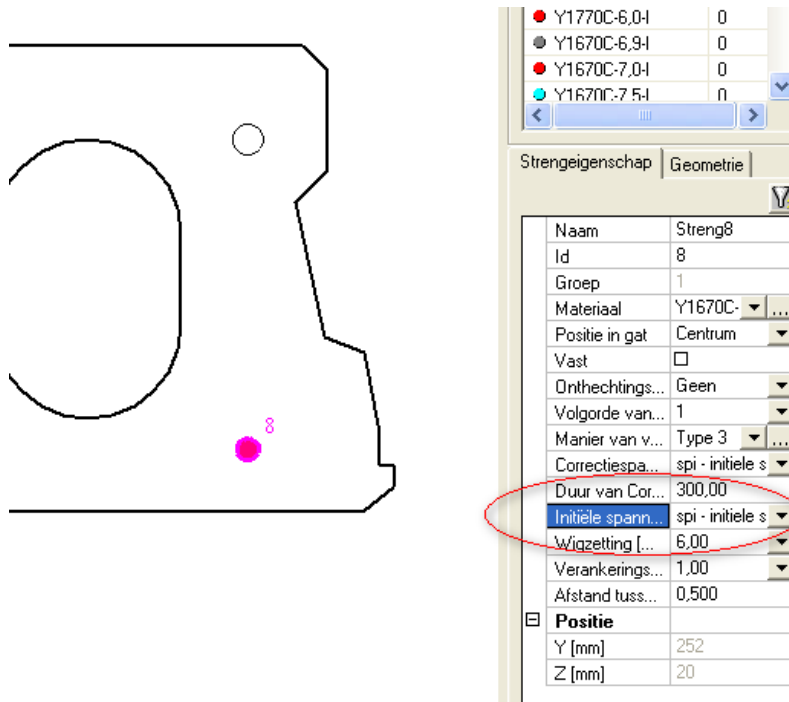

- **Line loads:**

Type: line load

Value:

- wall: -0,5 kN/m
- casting coating: -1,75 kN/m
- long term var: -1,75 kN/m

- **Time of prestressing**

Type: time (history)

Value: 1 day

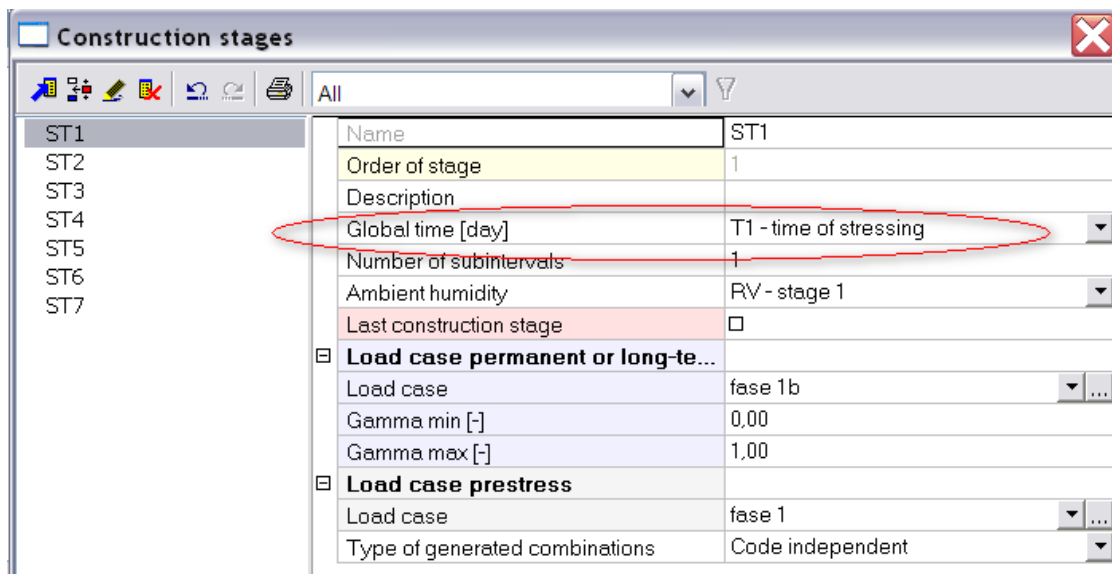

- **T2 up to and including T7:**

Type: time (history)
Value: 1,1; 1,2; 28; 50; 100; 18000

- **Relative humidity**





Type: relative humidity:
Value: 70 and 100%

- **Cross-section type**

Type: library

Method: make a 'master' cross-section (copy of the original cross-section) and use the option 'possible alternative'.





Subsequently it can be used with parameters as follows:

Name	CS
Type	Library
Description	section
Library	Cross-Sections 
Value	master - General cross-section 
Alternative	CS2 - Grafische doorsnede 
Select Alternatives	
Alternative no. 1	master
Alternative no. 2	VS150
Alternative no. 3	VS151
Alternative no. 4	CS2

- **Strand pattern**

Type: library

Method: idem as the cross-section type. Make various strand patterns and copy a type as a master case.

Name	BGP
Type	Library
Description	bore hole pattern
Library	Sectional strand pattern 
Value	master 
Alternative	SSP 
Select Alternatives	
Alternative no. 1	SSP
Alternative no. 2	SSP1

Analogous possibilities for the type of library are: materials, stressing beds, bore hole patterns, ...

Other possibilities to parameterize:
Moment of casting, Moment of releasing the casting

7. Making openings in de hollow core slab

Two openings are made, of which a number of values are parameterized, sc:

- **delta x:**

Type: length
Value: 1m

- **Width, length and depth opening:**

Type: cross-section length
Value: 500 and 150 mm

- **x_offset:**

Type: cross-section length
Formula: -width/2

- **x_hole:**

Type: length
Value: 2,1 m

- **n_hole:**

Type: integer
Value: 2

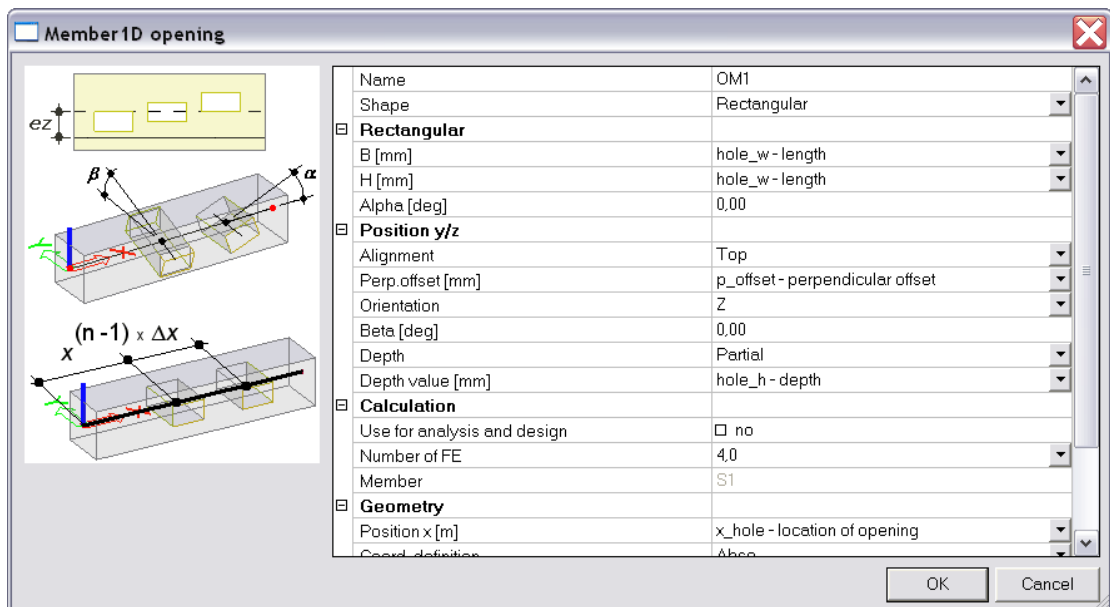

8. Using the template dialog

Subsequently these parameters can be divided and the template dialog can be used:

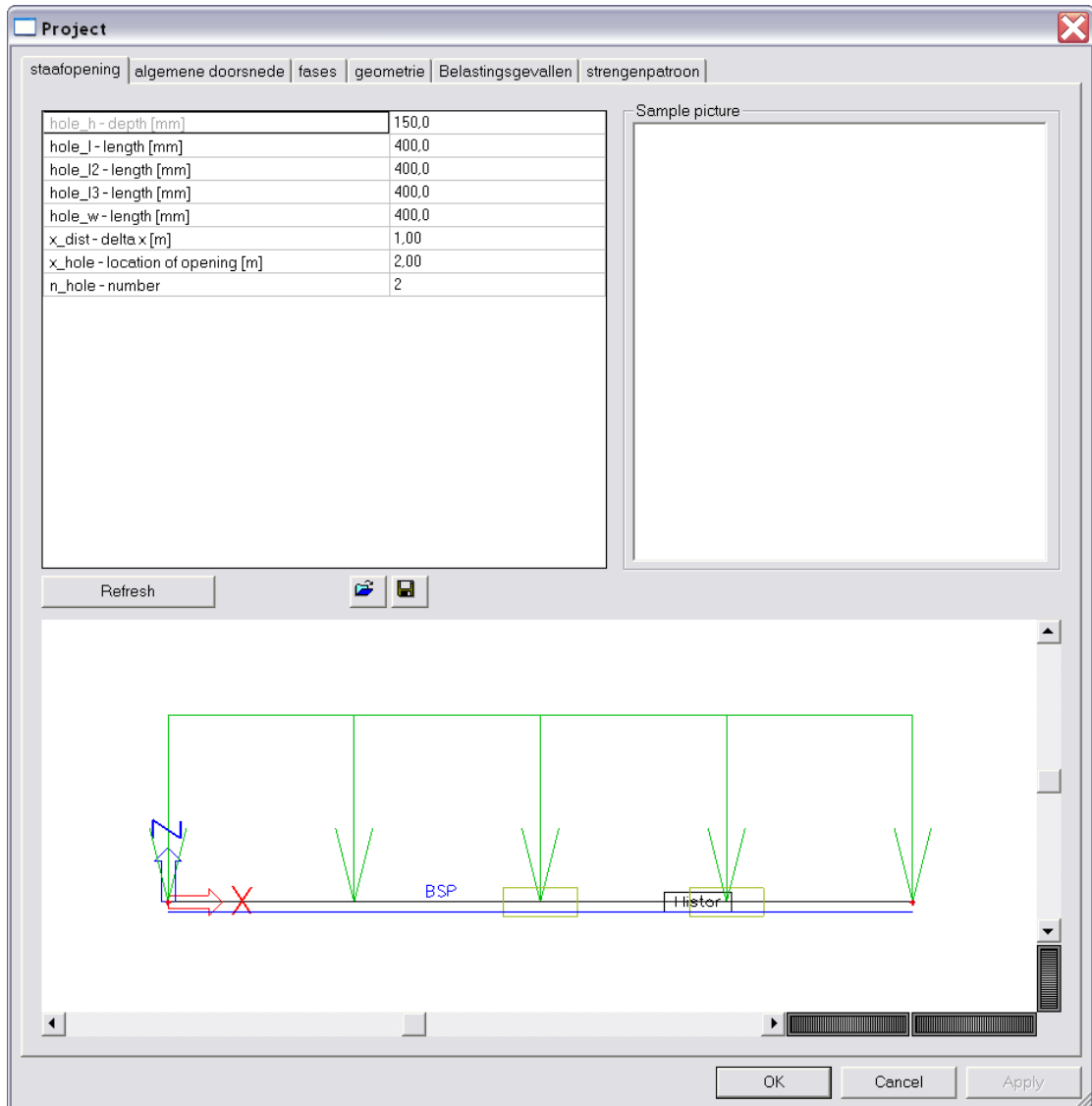

9. Different number of spans

Now the number of spans can be adjusted by means of copying the hollow core slab and to divide it into layers. For example: 3 elements.

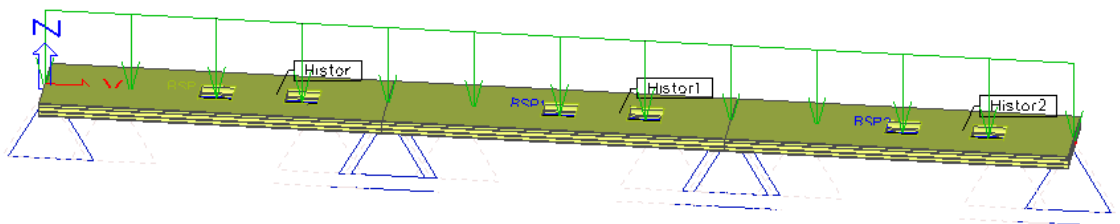

Subsequently the following parameters can be used:

- N: number of spans

Type: integer

Value: 3

- Activities of the various layers:

Type: boolean

Evaluation: formula

A1: $N \geq 1$

A2: $N \geq 2$

A3: $N \geq 3$

- Construction type of the various layers:

Type: boolean

Evaluation: formula

C1: $\text{not}(A1)$

C2: $\text{not}(A2)$

C3: $\text{not}(A3)$

XML

SCIA Engineer allows for the exchange of data with third-party applications through the popular and powerful XML format. Moreover, XML format can be used to develop tailor-made applications that use SCIA Engineer as a "hidden" engine working on the background and performing calculations of company-specific problems.

The XML file editor is very similar to the Document of SCIA Engineer. The principle is that the user defines tables describing individual entities of the SCIA Engineer projects and their order. This table-form can be easily previewed (it is in fact identical to the standard SCIA Engineer document). When ready, the final XML file contents can be transformed into the real XML format through the export function.

- Take example 8 again: steel frame.esa

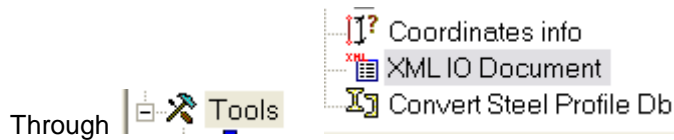

XML Input / Output Document

DOC-Default

Default

Parameters

New Close

Name	Parameters
Caption	Parameters
Visible	yes
Prefer one page	<input type="checkbox"/>
Filter	All

Actions

Refresh >>>

Ready [en]

1. Parameters

Name	UniqueID	Type	Evaluation
H1	{5A0826EE-1820-4458-9086-31781F326D32}	Length	Value
H2	{B4D32D70-36E7-4512-B1D1-A7193ADD5A18}	Length	Value
Htot	{9472EB82-54C7-4D48-AE09-E570F4D24E66}	Length	Formula
L	{676B5CB5-B211-44F2-B74B-3C965301B56A}	Length	Value
NS	{8E25ED26-1A55-4CF6-8BD4-5353B39CA8F1}	Integer	Value
S	{4A3FD994-A184-40F7-A7A0-D97607CA2AC6}	Length	Value
S1	{DCF03F45-0036-49A9-AB9E-24D0723A0605}	Length	Formula
S2	{3A20EBF8-F846-42E7-A9FE-7894DA6257D9}	Length	Formula

- Export to XML:

```

- <obj id="4" nm="L">
  <p0 v="L" />
  <p1 v="{676B5CB5-B211-44F2-B74B-3C965301B56A}" />
  <p2 v="3" t="Length" />
  <p3 v="0" t="Value" />
  <p5 v="0" />
  <p6 v="Length" />
- <p7 t="">
- <h>
  <h0 t="Real" />
  </h>
  <row id="0">
    <p0 v="10" />
  </row>
</p7>
- <p8 t="">
- <h>
  <h0 t="Real" />
  </h>
  . . . . .

```

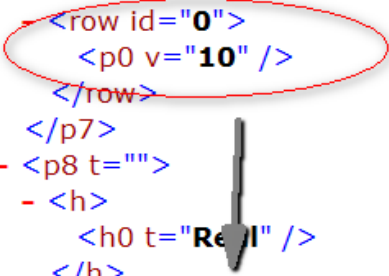

- Adjusting the parameter L: 10 → 20

Remark:

For this purpose, it's necessary that the XML-document is opened in a text-file, for example: notepad.

```

<obj id="4" nm="L">
  <p0 v="L" />
  <p1 v="{676B5CB5-B211-44F2-B74B-3C965301B56A}" />
  <p2 v="3" t="Length" />
  <p3 v="0" t="Value" />
  <p5 v="0" />
  <p6 v="Length" />
  <p7 t="">
  <h>
  <h0 t="Real" />
  </h>
  <row id="0">
    <p0 v="20" />
  </row>
</p7>
  <p8 t="">
  <h>
  <h0 t="Real" />
  </h>
  <row id="0">
    <p0 v="-1000000" />
  </row>
</p8>

```

- Regenerate the project through 'File > Update > XML file'. You will see that the structure has been changed now.

ODA

Oda is the abbreviation of 'One dialog application'. It's also called the SCIA engineer Template.

It can be used for following type of projects:

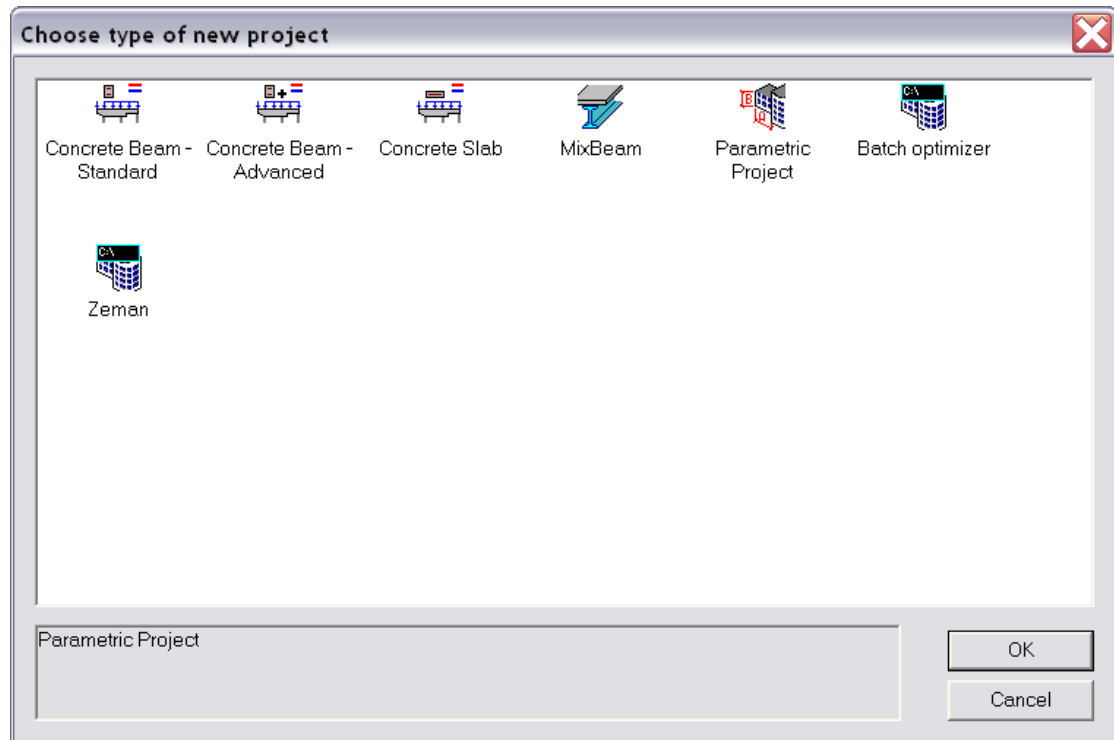

In this workshop the options 'Parametric project' and 'Batch optimizer' will be used. The Batch optimizer will be explained in the next example.

The main principle of ODA is as follows:

- In SCIA Engineer a project is made, eventually with parameters and with document, and saved as a template.
- After this, SCIA Engineer has to be closed. It's not possible to open the same project in ODA and in SCIA Engineer at the same time.
- Now, ODA can be opened and the user has to choose the type of project.
- In the most used case 'parametric project', the user can change the value of the parameters and the result is a document with all the added tables.
- This is shown in the following model.

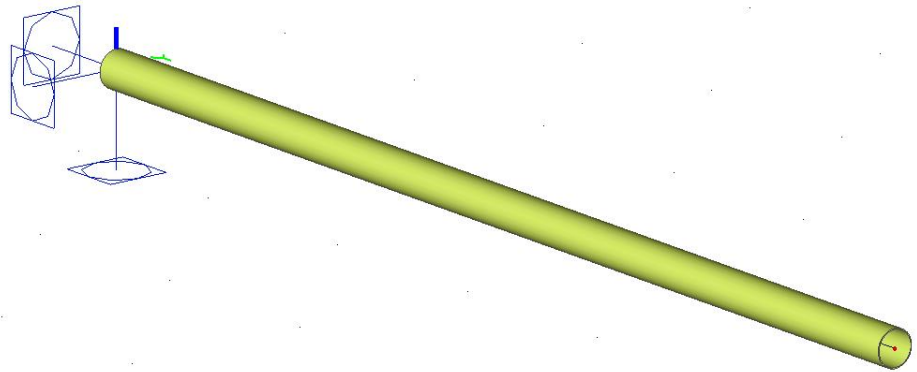

- Project data:
 - Construction type: General XYZ
 - Project level advanced
 - Material: concrete C20/25
- Functionalities – Parameters
- Load cases:
 - Selfweight
 - Variable line load: 1 kN/m
- Combinations: UGT and BGT
- Document input:
 - Nodes
 - Load cases
 - Combinations
 - Internal forces: My
 - Deformations: uz
- Parameters:
 - Diameter cross-section: 200 mm
 - Thickness cross-section: 5mm

Method

- Save this project, e.g. Oda.Esa, in the folder 'Templates' and close (if this is not performed, a conflict will arise when opening ODA).
- then open the program SCIA ODA:



- The following dialog box appears:

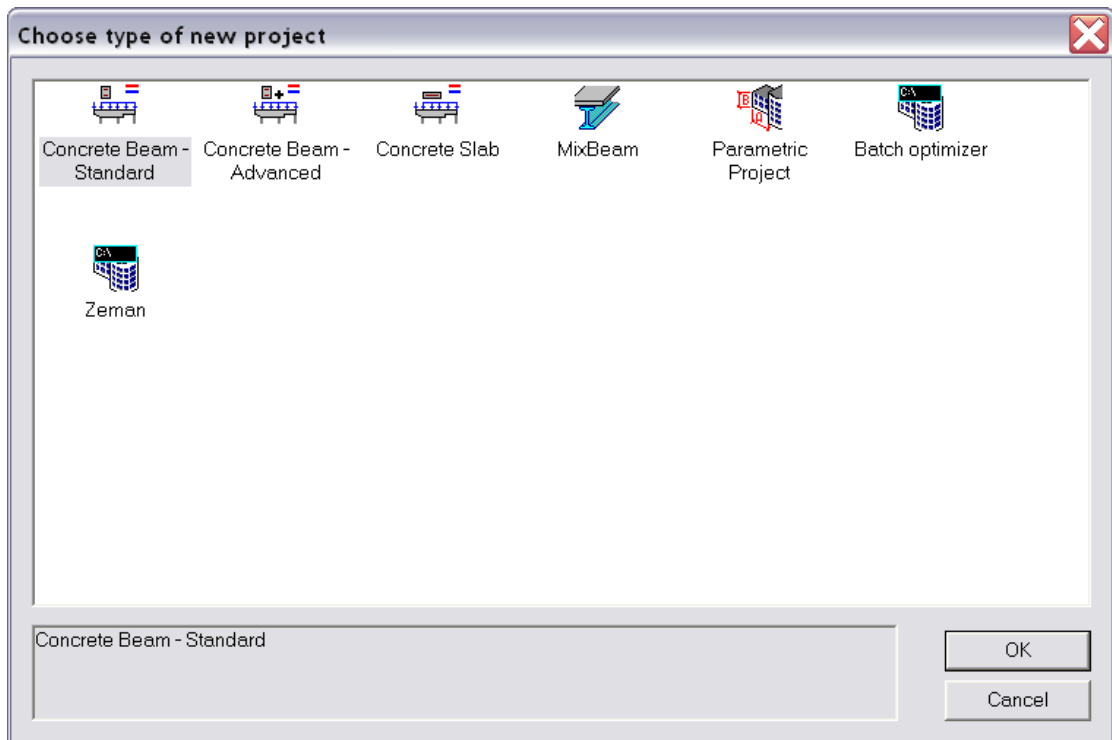

Choose the option 'Parametric project'.

- The following dialogue box appears:

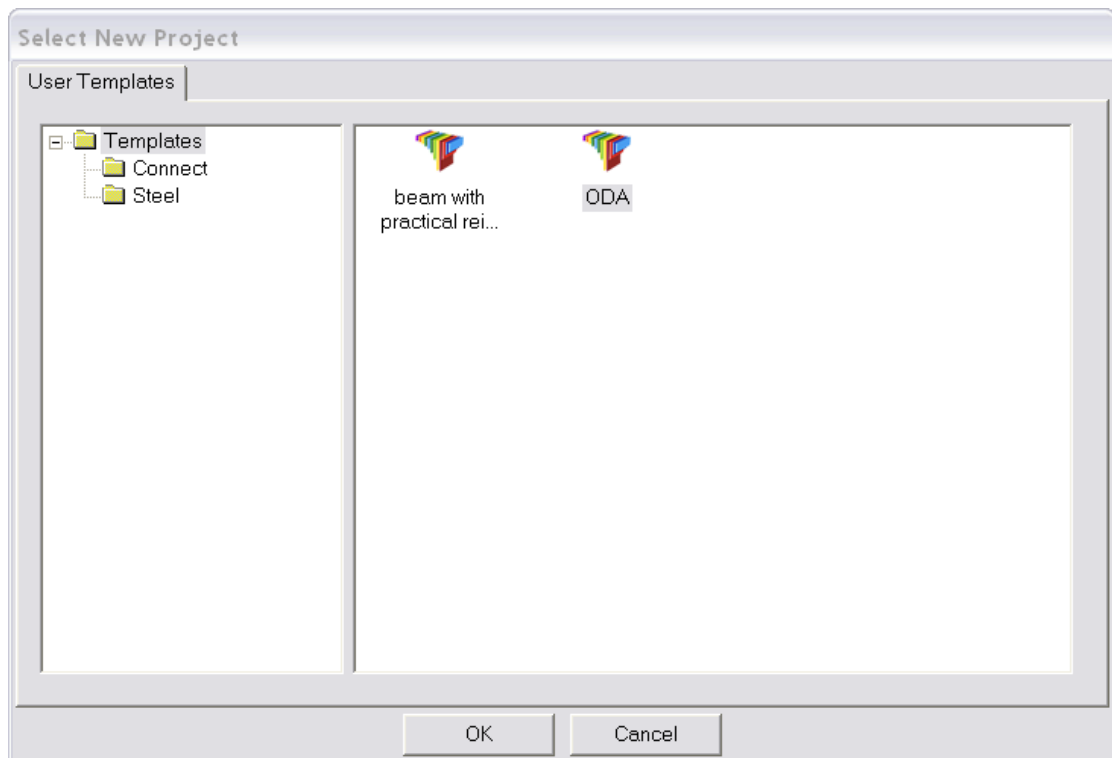

- Now the various steps can be re-run and possibly adjusted:

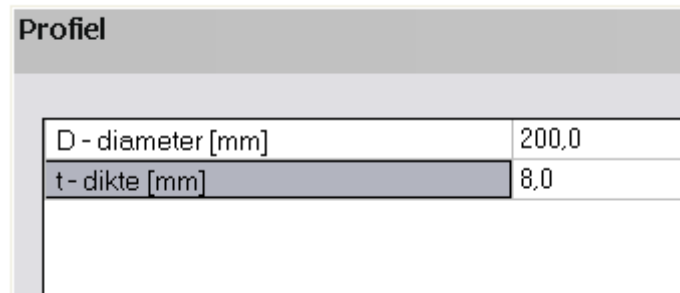
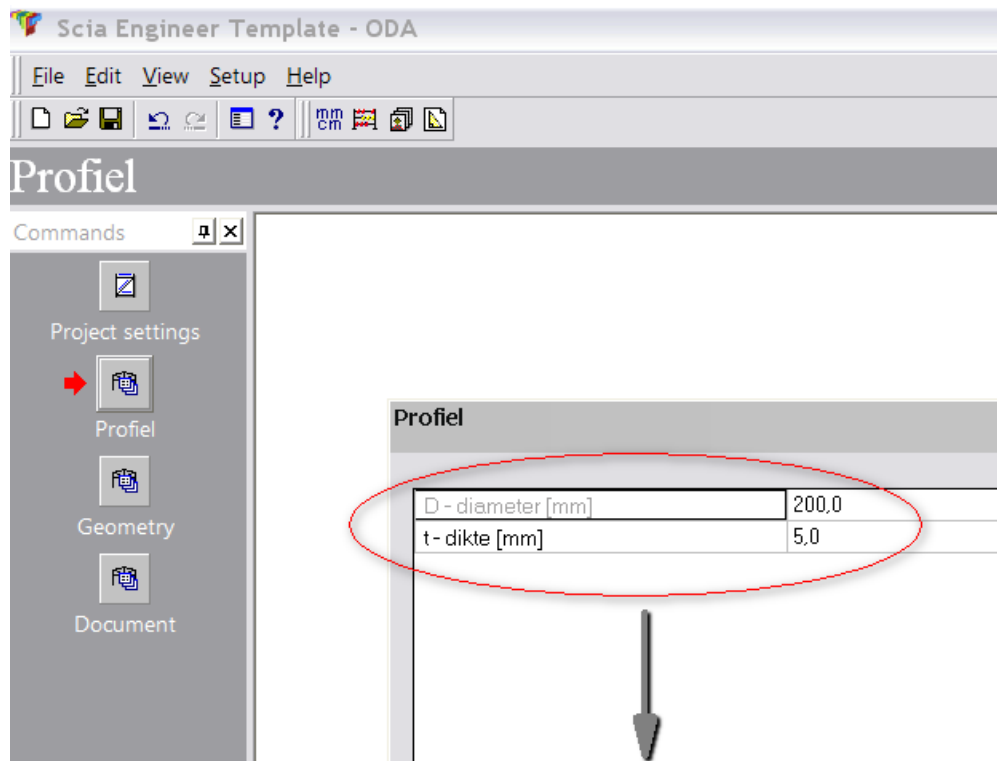

- Finally the following document is obtained in ODA after an automatic calculation:

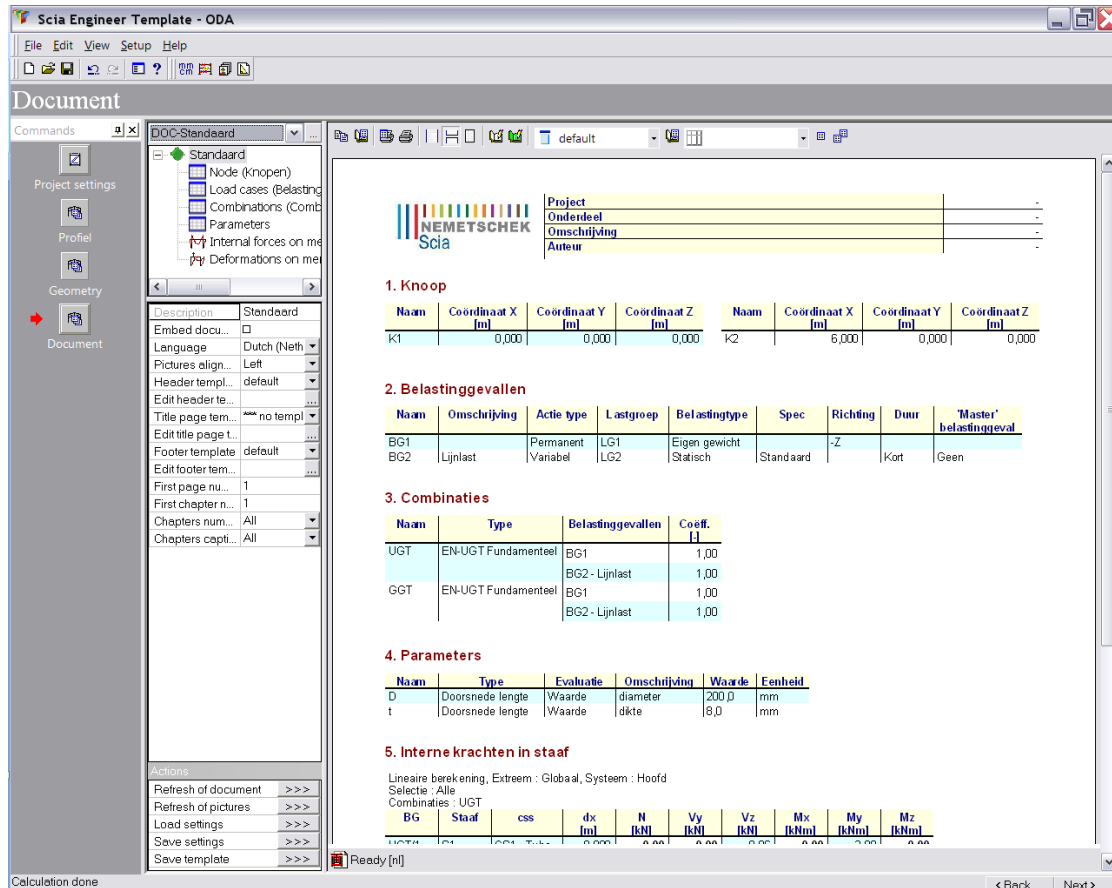

Note:

So, it's not possible to adapt the geometry on the graphical screen like we do in SCIA Engineer.
 In ODA, only the inserted parameters can be adapted.
 It's also not possible to add new tables in the document. ODA uses the document from the template.

Batch optimizer

The batch optimizer is a special function of ODA. First of all a parametric project is made in SCIA Engineer.

Then an input and output file has to be made in XML. Subsequently they can be read in ODA.

A begin and end value of the parameter can be filled in and an iteration step to be performed. The results are the values of the desired output parameter.

Example:

A beam on two supports is created in SCIA Engineer. The line load is parameterized. In ODA the moment M_y will be asked for a certain range of this parameter.

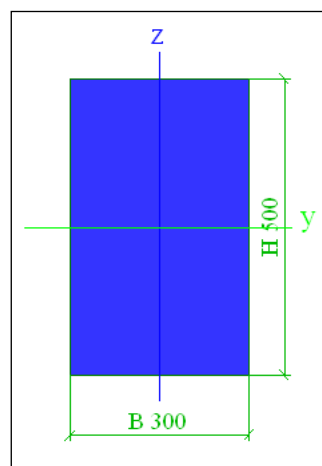
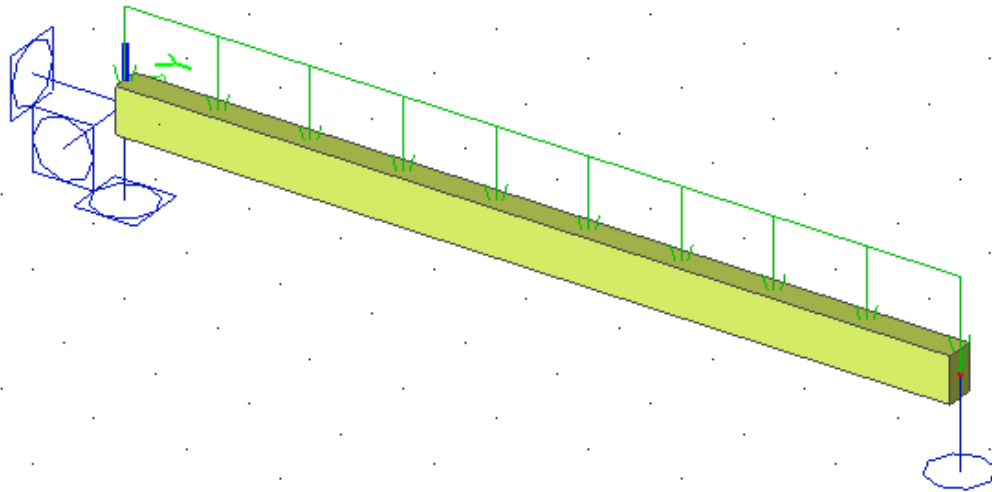

- Project data: - Construction type: Frame XYZ
- Project level advanced

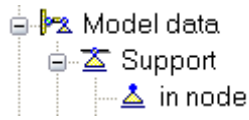

- Input support:

Method

- The line load is parameterized with a begin value of -5 kN/m
- Subsequently go to 'Tools > XML IO document' and export an input and output file:

Input file:

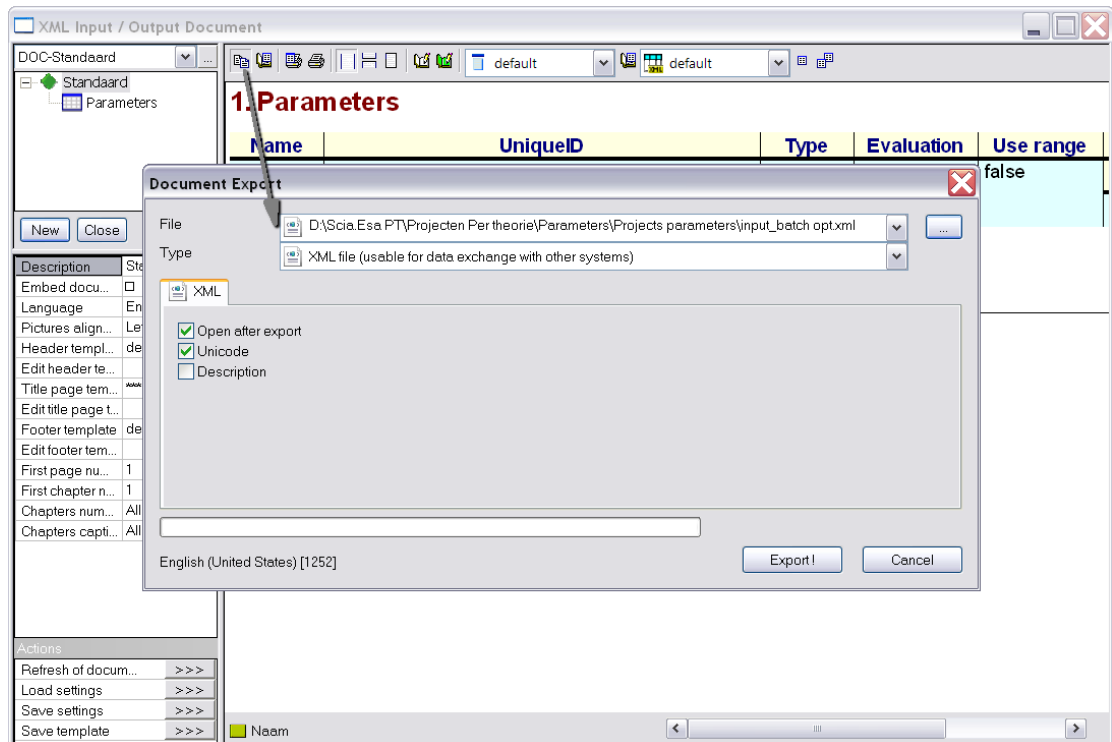
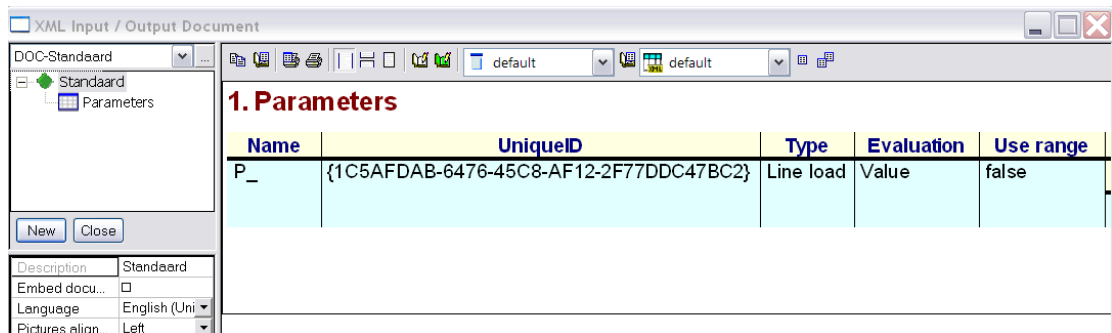

Output file:

The screenshot shows a software window titled "XML Input / Output Document". The main content area displays a table titled "1. Interne krachten in staaf". The table has columns for BG, Staaf, css, dx, N, Vy, Vz, Mx, My, and Mz. The data is as follows:

BG	Staaf	css	dx	N	Vy	Vz	Mx	My	Mz
BG1	S1	CS1 - RECT	1e-006	0	0	28112.52734	0	-50512.75	0
BG1	S1	CS1 - RECT	9	0	0	-16887.47266	0	0	0
BG1	S1	CS1 - RECT	5.4	0	0	1112.527344	0	28394.90039	0

On the left side, there is a sidebar with a tree view showing "Internal forces on me" and a list of properties for "Interne krach...".

The screenshot shows the same software window, but now displaying "1. Parameters". A table with columns "Name", "UniqueID", "Type", "Evaluation", and "Use range" is visible. The "Use range" column contains the value "false".

Overlaid on this is a "Document Export" dialog box. The "File" field contains the path "D:\Scia.Esa PT\Projecten Per theorie\Parameters\Projects parameters\output_batch opt.xml". The "Type" is set to "XML file (usable for data exchange with other systems)". The dialog has checkboxes for "Open after export" (checked), "Unicode" (checked), and "Description" (unchecked). The language is set to "English (United States) [1252]".

- This project can now be opened in ODA. For this, you choose the option 'Batch optimizer'.

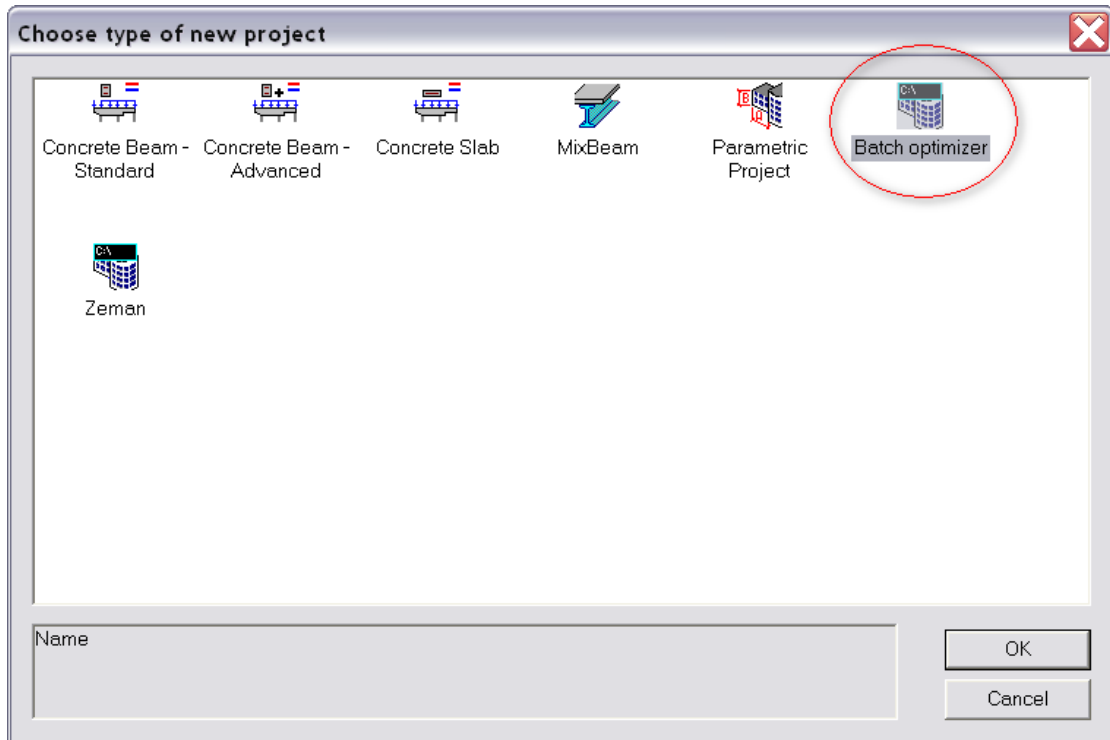

- Subsequently a dialog box appears in which the Esa project and both XML files have to be collected:

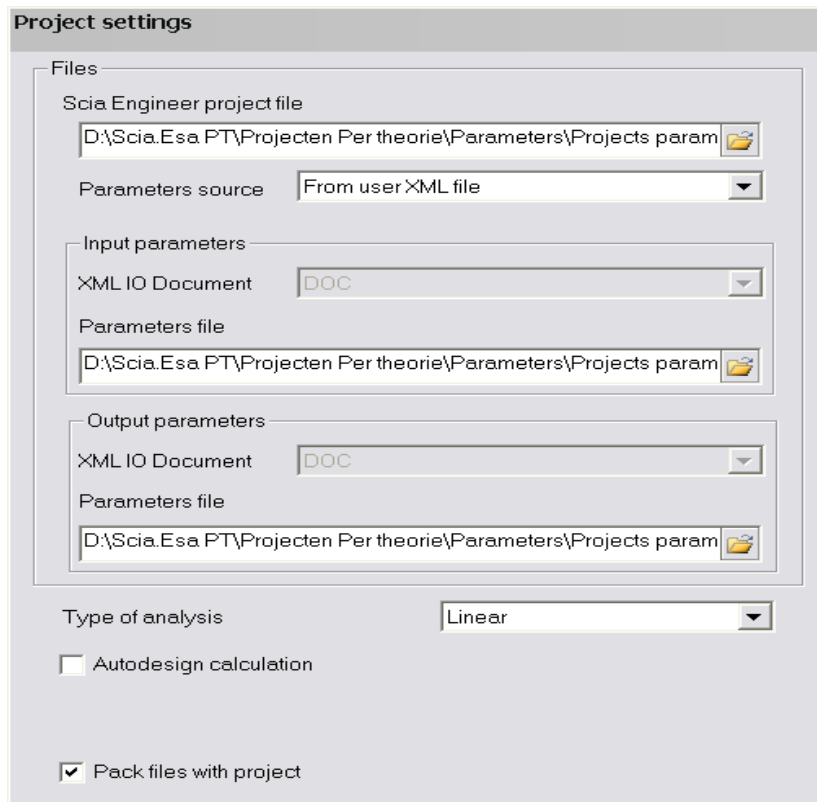

- If an optimisation was used in the Esa project, it can be taken into account here by selecting the option 'optimisation calculation'.

You can ask for the results for a number of values of the parameter. Here the parameter 'line load on member' can be used. A begin value of -5 and an end value of -10 can be taken with an iteration step 1.

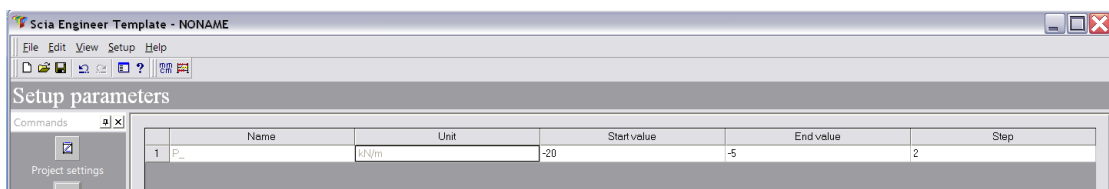
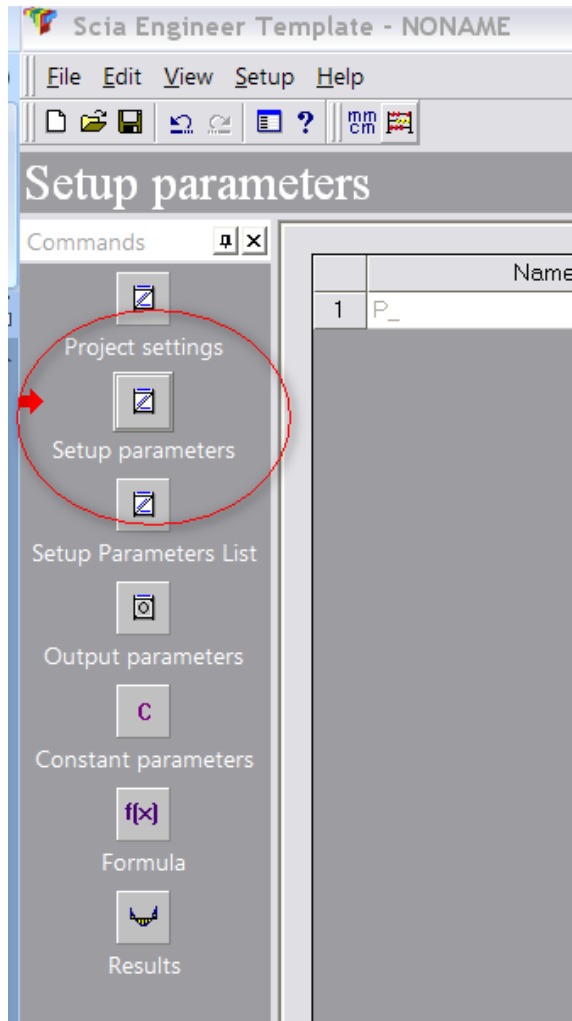

The values of the output XML file that have to be evaluated, can be marked. The values for My_max and My_min are checked.

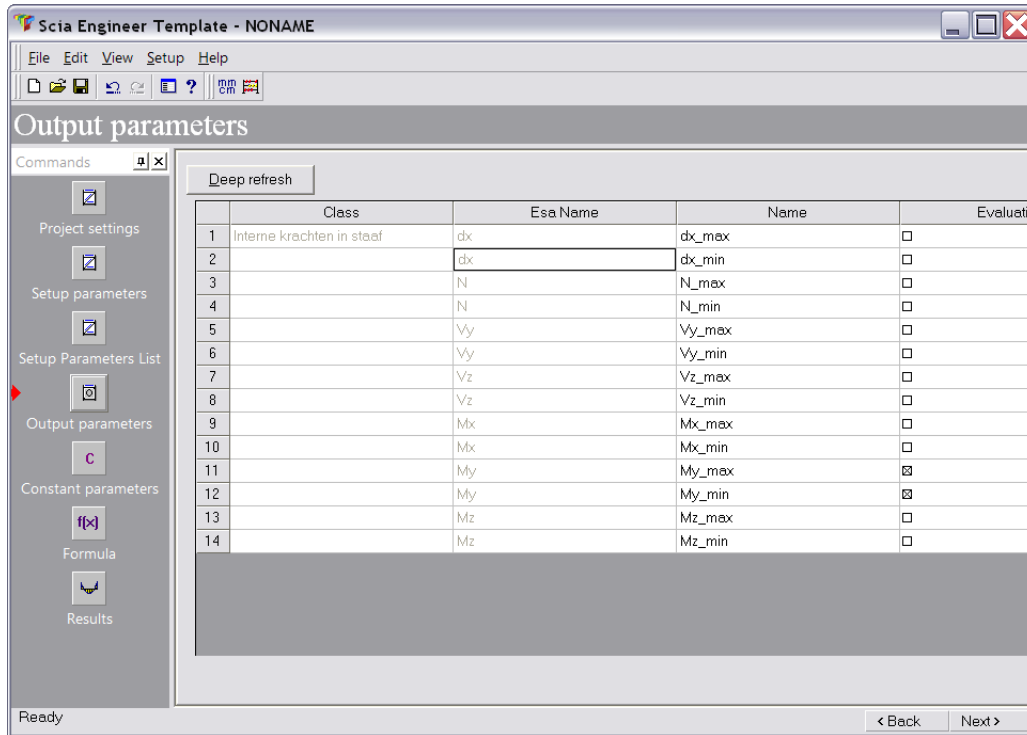

Possibly constant values and formulae can be inserted. They will be taken into account in the result table.

Finally you can go to the results, where a calculation is performed for the various line loads. This is performed in various iteration steps, which are executed independently from each other.

The result is as follows:

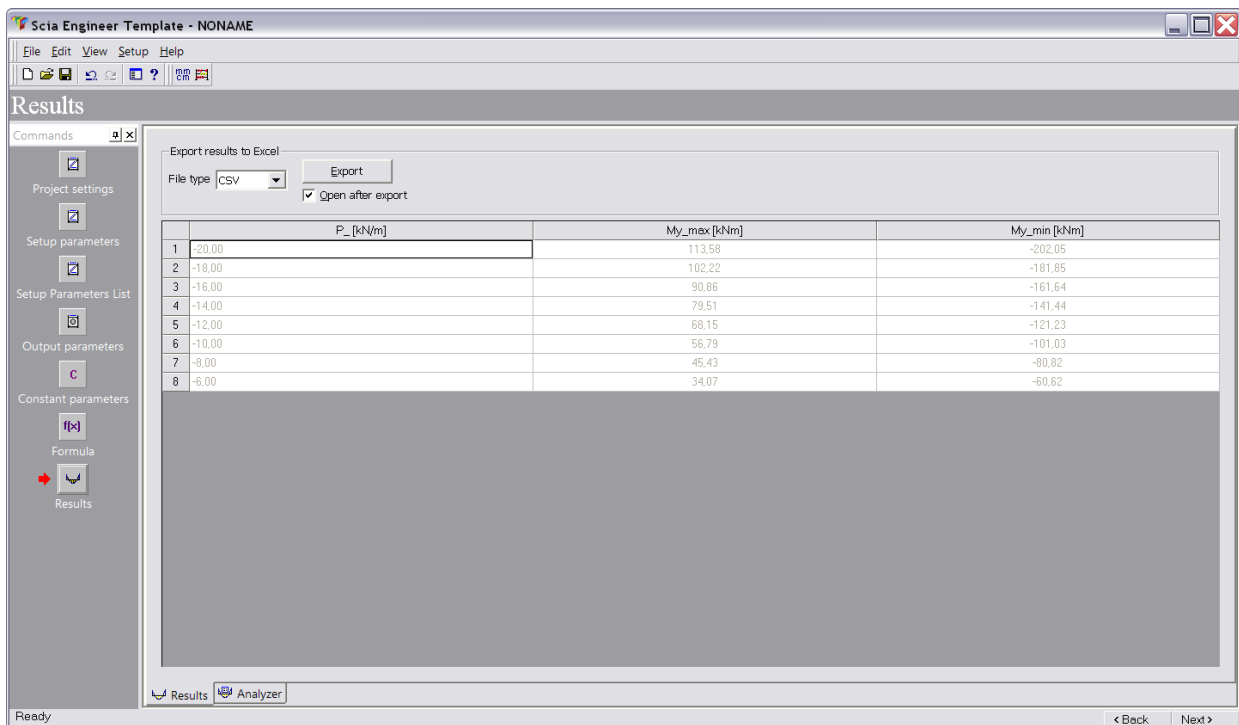

Example 14: User blocks & Project Templates

User blocks

SCIA Engineer enables the user to make a library of his/her projects that are used over and over again. These projects may be at any time included into a newly created project or appended to an earlier created and currently edited project. The projects in this user-created library are called **User blocks** and the library is called **User block library**.

We take example 8 again: **Steel frame.esa**

Save as user block:

'File > Save as ' and then save in the file userblocks.

You can find it in:

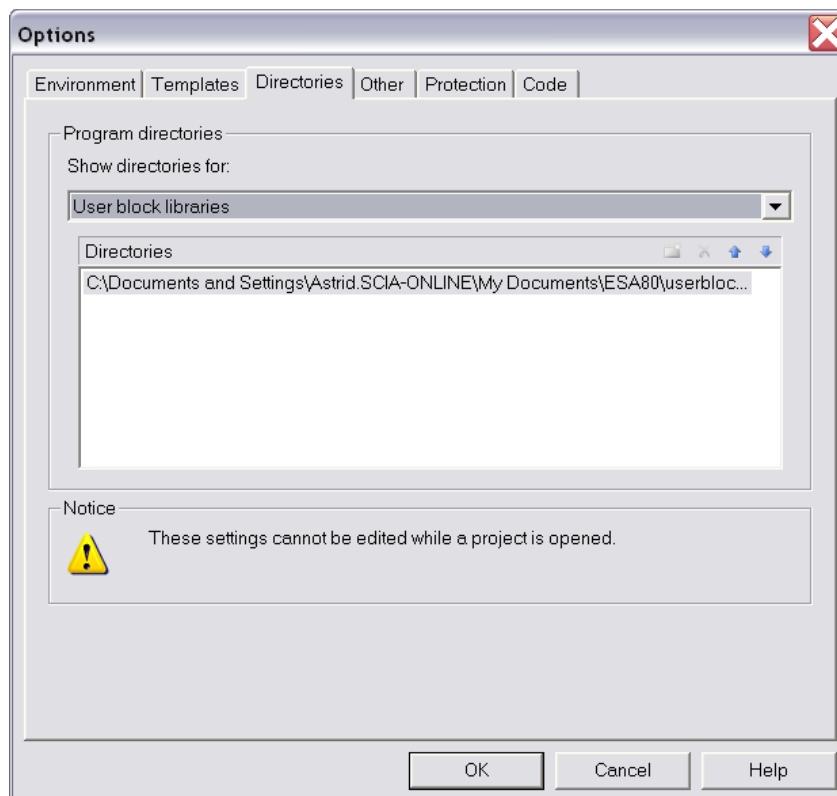

- Make a new project, e.g. in general XYZ
- Open the Structure menu :



The following dialog boxes appear:

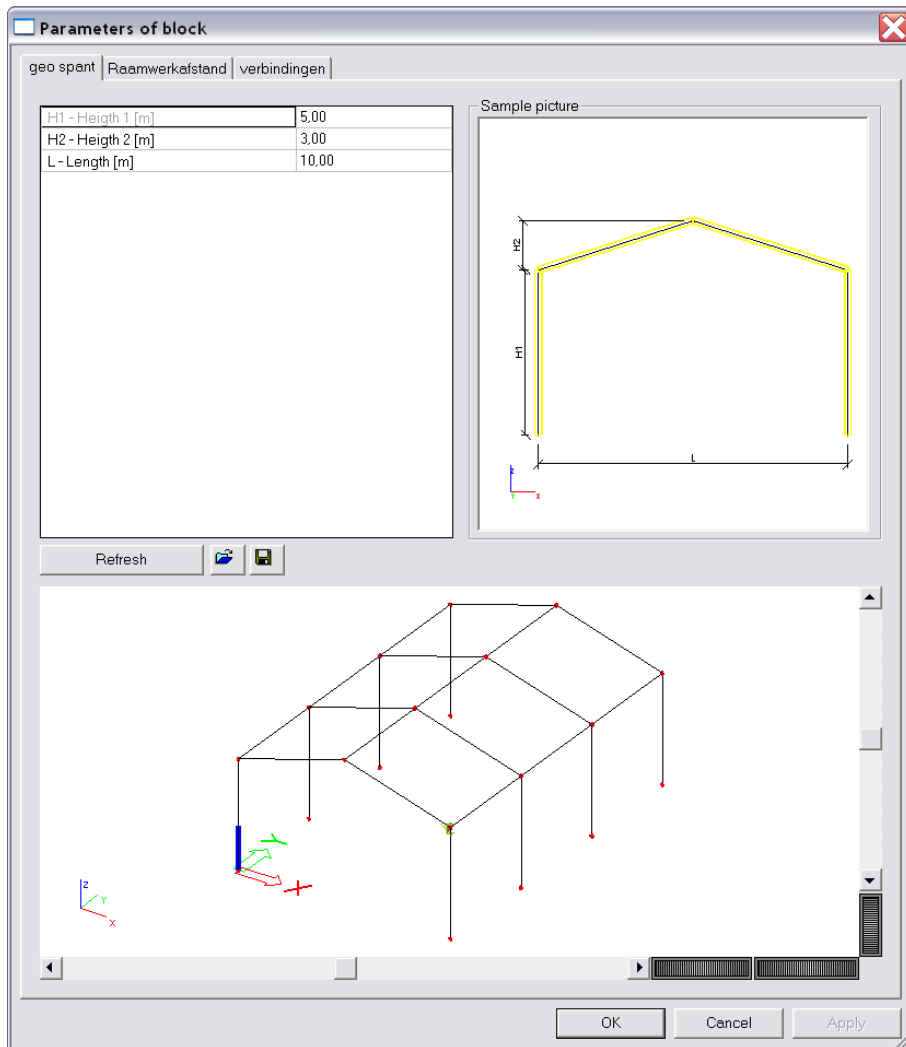
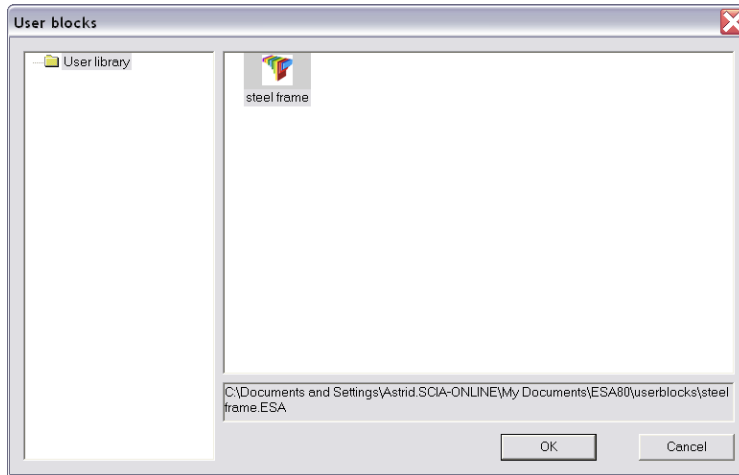

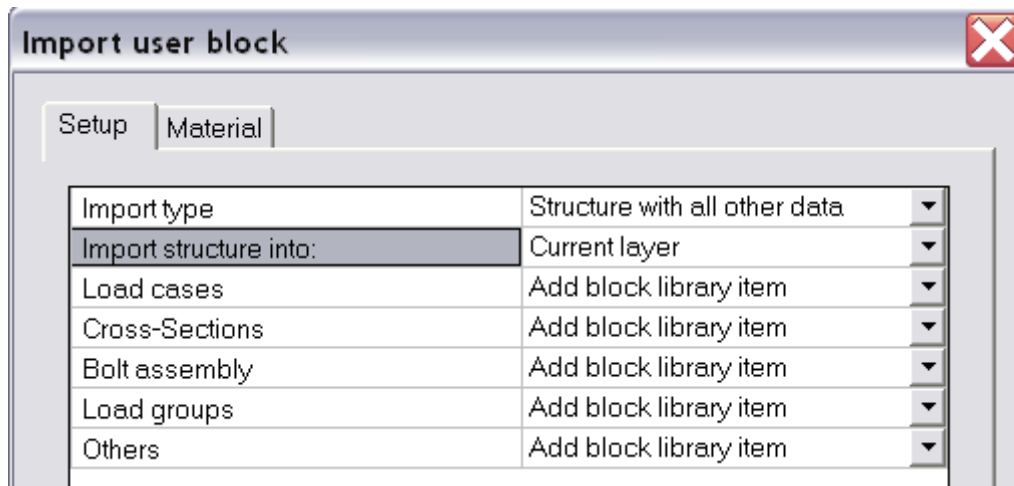

- Insert another user block
 - with NS = 3
 - frame distance = 8 and NS = 4
 - length L = 15 and NS = 3
- Here you can get the following example:

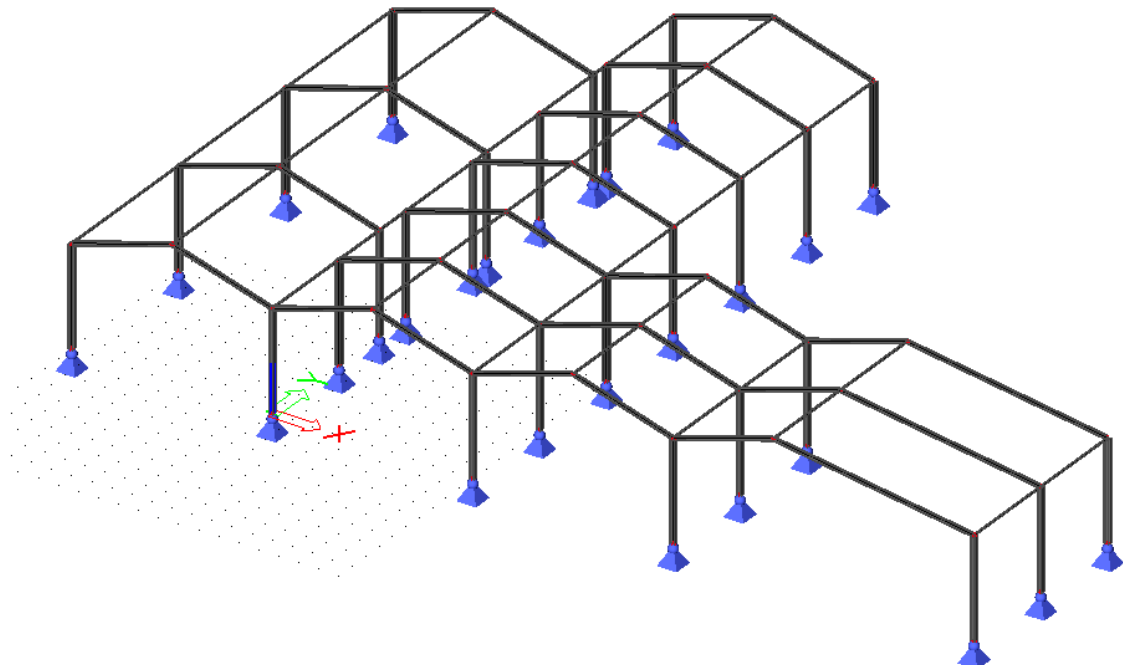

Project templates

In practice it may quite often happen that some elements are used in every project. For example, material types, cross-sections, predefined loads, and even parts of a structure may be the same in various projects. Therefore, it would be efficient, if the user could store the repetitious elements aside and load them quickly into every new project.

In SCIA Engineer this may be achieved via templates. Generally speaking, a template is an ordinary project that holds required information and is saved in a special way.

Let's take example 8 again: Steel frame.esa

- Save as template: 'File > Save as' in the folder:

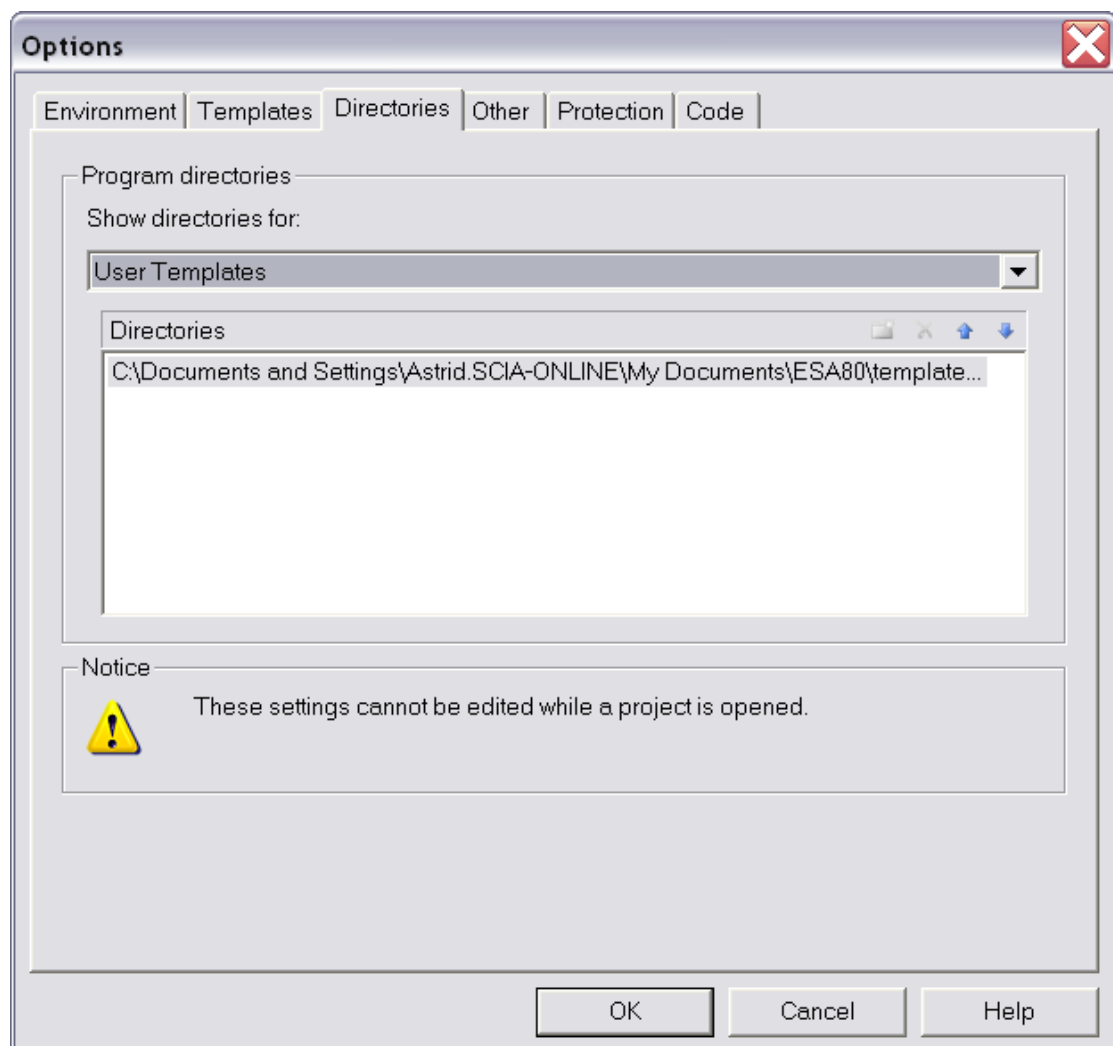

- Close example 8 and open a new project. Go to the tab 'User templates'.

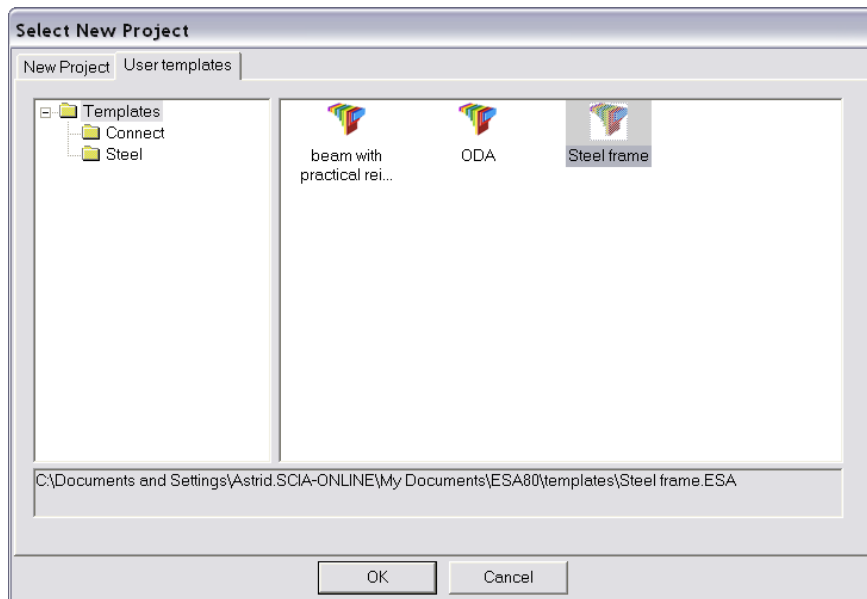

- When opening this template, also here a dialog box appears with possible parameters that can be adjusted:

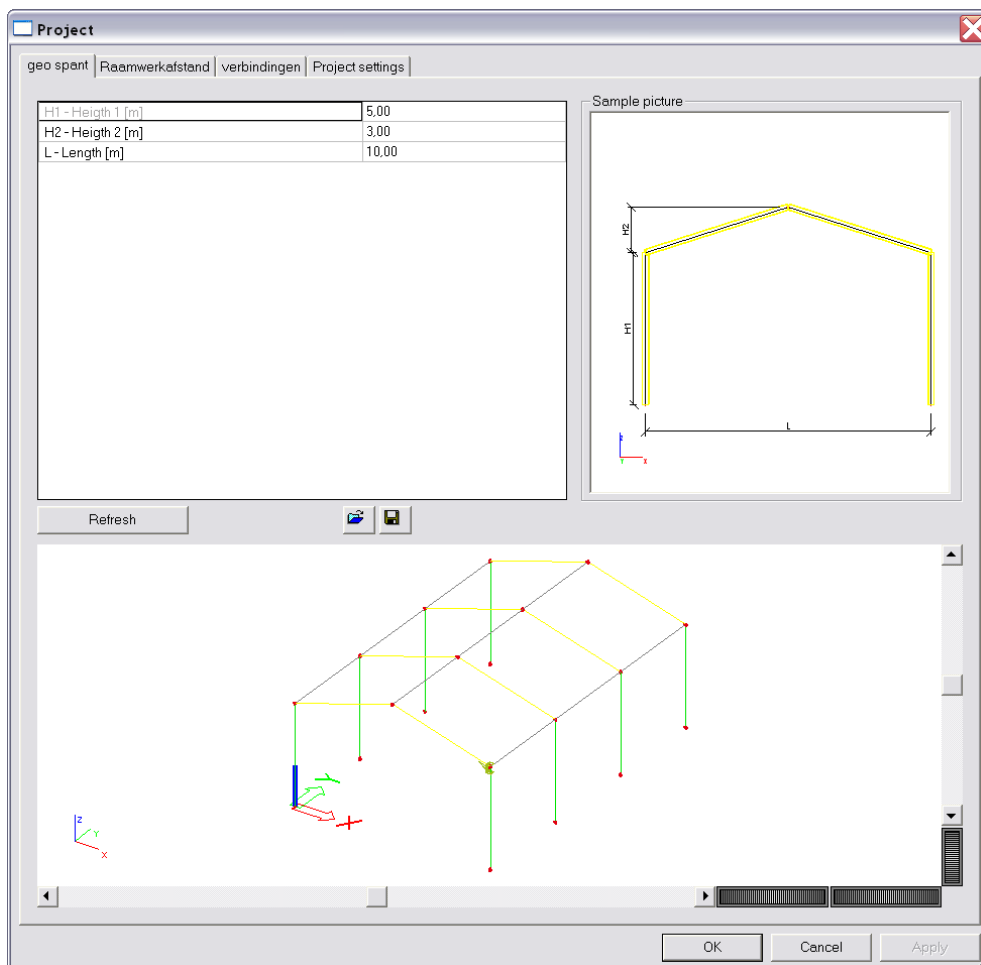

General parameterizing

If you doubt if a certain property can be parameterized or not, it is advisable to create as many types of parameters as possible that can possibly be the required parameter.

Type of parameters:

Parameter types

Nothing	The parameter is not used.
Integer	The parameter is used as an integer.
Coefficient	The parameter is used as coefficient.
Length	The parameter is used for definition of length in the model.
Force	The parameter is used for definition of size of force load.
Moment	The parameter is used for definition of size of moment load.
Line load	The parameter is used for definition of size of line load.
Surface load	The parameter is used for definition of size of surface load.
Mass	The parameter is used for definition of size of masses.
Line mass	The parameter is used for definition of size of line masses.
Surface mass	The parameter is used for definition of size of surface masses.
Cross-section length	The parameter is used for definition of length at cross-sections.
Angle	The parameter is used for definition of angles.
Relative	The parameter is used for definition of relative values.
Cross-section rolled	The parameter is used for definition of cross-sections.
Library	This parameter type can be used with any "library" item, i.e. any item that is selected from one of ESA PT's internal databases, such as materials, cross-sections, subsoil, reinforcement pattern, etc.
Combination factor	Combination factors for load cases inserted into a combination.
Relative humidity	applicable in the calculation of long term losses in prestress.
Time (history)	Time of individual construction stages on time-line.
Stress	(i) Stress in concrete that can be defined in measured values when the Time Dependant Analysis is performed or (ii) the initial stress of the strands for a strand pattern.

Possible formulae:

+	Adds the given numbers / parameters
-	Subtracts the given numbers / parameters
*	Multiplies the given numbers / parameters
/	Divides the given numbers / parameters
\	Modulo – gives the remainder after division of two numbers
^	Raises the given number to a given power
()	Putting individual members of the expression may change the priority of evaluation.
sin(x)	Calculates the sine of parameter x
cos(x)	Calculates the cosine of parameter x
tan(x)	Calculates the tangent of parameter x
tg(x)	
arcsin(x)	Calculates the arcsine of parameter x
asin(x)	
arccos(x)	Calculates the arccosine of parameter x
acos(x)	
arctan(x)	Calculates the arctangent of parameter x
arctg(x)	
atan(x)	
atg(x)	
ln(x)	Calculates the natural logarithm of x.
log(x)	Calculates $\log_{10}(x)$.
exp(x)	Calculates the exponential e to the x-th power.
sign(x)	Returns the sign of parameter x. Returns +1 for positive argument. Returns -1 for negative argument.
sgn(x)	
sqrt(x)	Calculates the positive square root of parameter x.

Possible operators in SCIA Engineer:

✚	"+"	ADD;
✚	"-"	SUB;
✚	"*"	MUL;
✚	"\\"	MOD;
✚	"/"	DIV;
✚	"^"	POW;
✚	"<"	LESS;
✚	"<="	LESS_OR_EQUAL;
✚	"=="	EQUAL;
✚	"<>"	NOT_EQUAL;
✚	">="	EQUAL_OR_BIGGER;
✚	">"	BIGGER;
✚	"&&"	AND;
✚	" "	OR;
✚	"^^"	XOR;

Example of a formula:

✚	$(W_S==1)*HW+(W_S==0)*(W-100)$
	<ul style="list-style-type: none"> • If $W_S=1$ then $H_BL=HW$ • If $W_S=0$ then $H_BL=HW-100$

Name	H_BL
Type	Length
Description	Höhe Borlochprofil
Evaluation	Formula
Formula	$(W_S==1)*HW+(W_S==0)*(HW-100)$
Value [m]	99.999
Use range	<input type="checkbox"/>

